



Achieve Compliance & Conformance with Dam Buster Products

NOTE: All Dam Buster® products are protected by various Australian and International Patents.



This document is to be read in conjunction with the Dam Buster publications titled 'Product Technical Statement' and 'Evidence of Suitability.' This installation manual sets out installation requirements for Dam Buster's products.

DAM BUSTER INSTALLATION MANUAL

Version 6.0 (3 April 2024)



CERTIFIED PRODUCT
(DAMBUSTER RAINHEAD)

For testing of the Overflow Performance of Dam Buster rectangular rainheads.



PRODUCT DESIGN
HARDWARE AND BUILDING
DAM BUSTER
RAINHEAD

"The Architectural Choice"

For ordering, installation details and compliance documentation, visit
www.dambuster.com.au

Dam Buster Roof Drainage System - Installation manual

	Page
Dam Buster Roof Drainage System Product Range	3-5
Safety Information & Disclaimer	6
1.0 Dam Buster Rainhead overflow device	
1.1 – Installation Method Options for the Dam Buster Rainhead	7
1.2 – Installation Method 1 and common installation instructions for each installation method	8-12
1.3 – Installation Method 2	13
1.4 – Installation Methods 3A & 3B	14 - 17
1.5 – Installation of eaves gutters to a Dam Buster rainhead	18
2.0 Dam Buster Side Outlet and Rainhead overflow device	
2.1 Installation of the Dam Buster Side Outlets	19-27
3.0 Dam Buster Sump overflow device	
3.1 Installation of Dam Buster Sumps	28-35
4.0 Dam Buster upstream devices	
4.1 Installation of the Dam Buster Elbows	36 - 41
4.2 Installation of Dam Buster Junctions	39

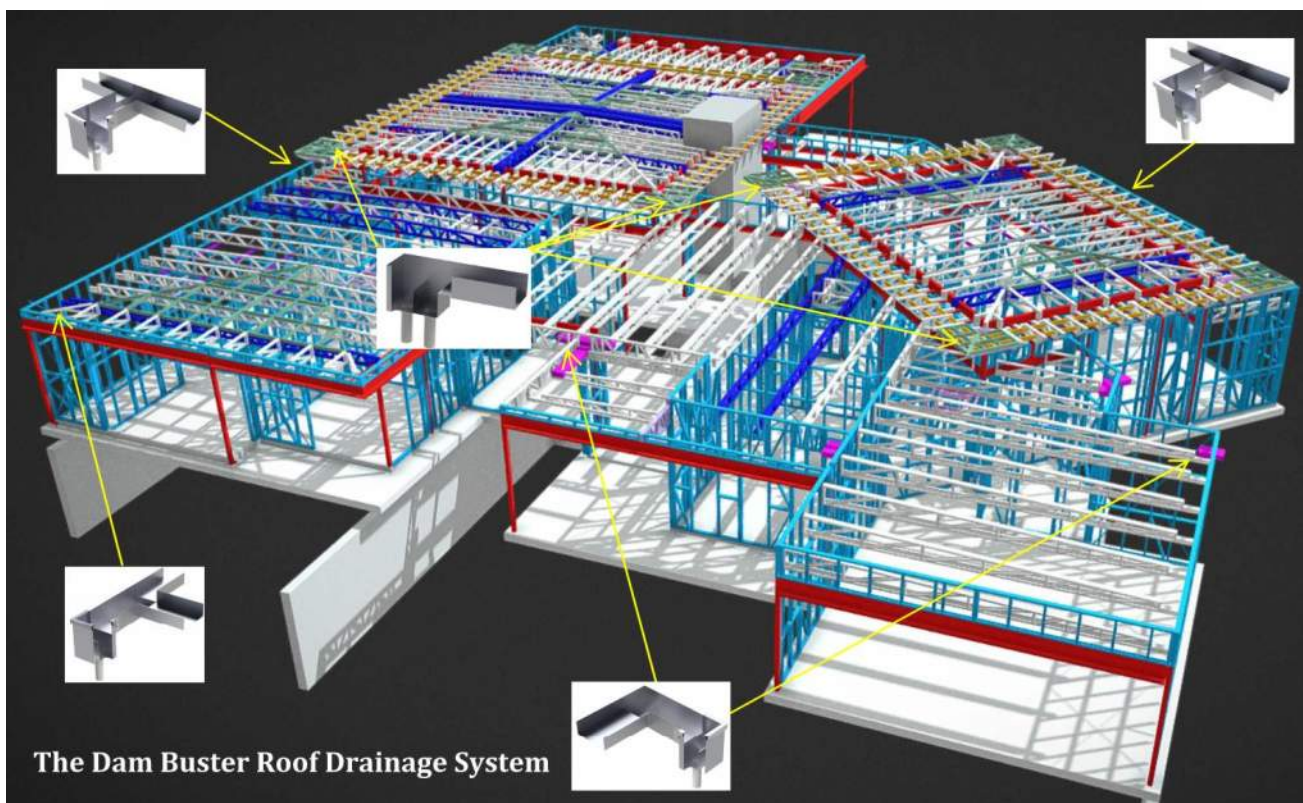

NOTE

Where this document refers to any code, guide or manual, this reference should be interpreted as being for the current legal version of the code, guide or manual for the relevant state or territory, unless noted otherwise.

Dam Buster Roof Drainage System - Product Range

Overflow devices (1 of 2)

Protected by various Australian and International Patents



Dam Buster Rainhead



Dam Buster Curved Fronted Rainhead

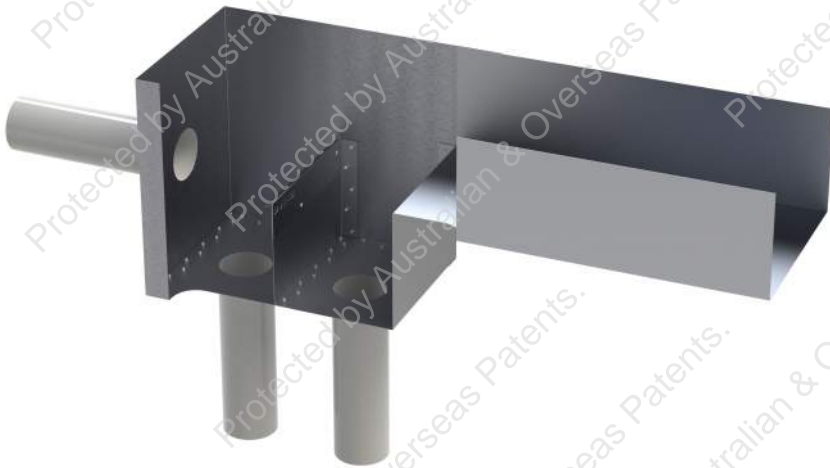

Dam Buster Sump

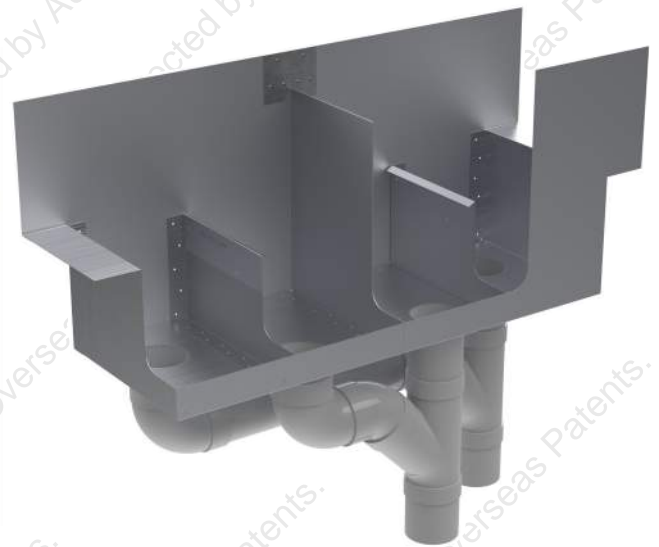

Dam Buster Back-to-Back Sump



Dam Buster Continuous Sump

Dam Buster Roof Drainage System - Product Range (cont)

Overflow devices (2 of 2)

Protected by various Australian and International Patents

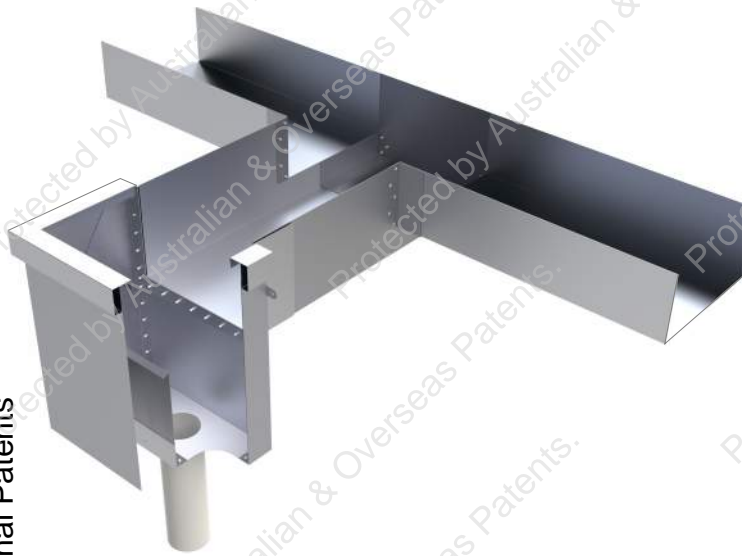

Dam Buster T Side Outlet & Rainhead

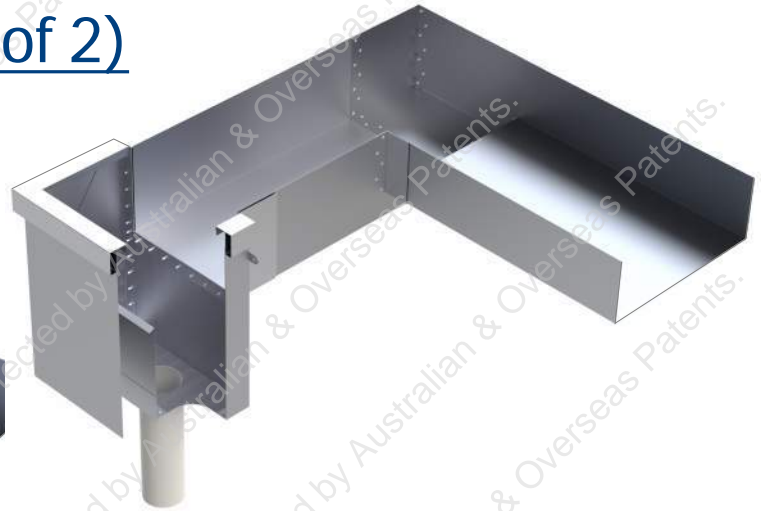

Dam Buster END Side Outlet & Rainhead (LH & RH forms available)



Dam Buster CORNER Side Outlet & Rainhead (LH & RH forms available)

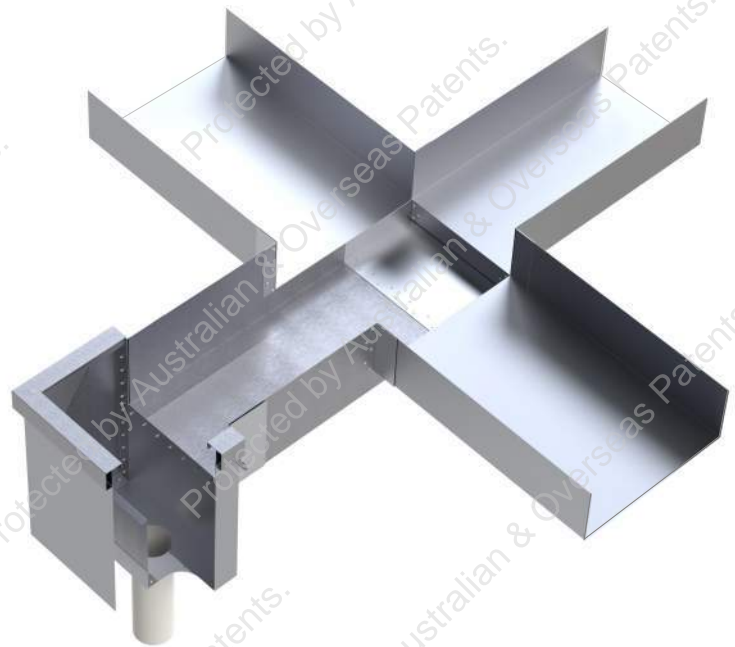

Dam Buster CRUCIFORM Side Outlet & Rainhead



Dam Buster END Side Outlet & Sump (LH & RH forms available)

NOTE

The following Side Outlet & Sump combinations are also possible

Dam Buster T Side Outlet & Sump

Dam Buster Corner Side Outlet & Sump

Dam Buster Cruciform Side Outlet & Sump

Dam Buster Roof Drainage System - Product Range (cont)

Upstream devices

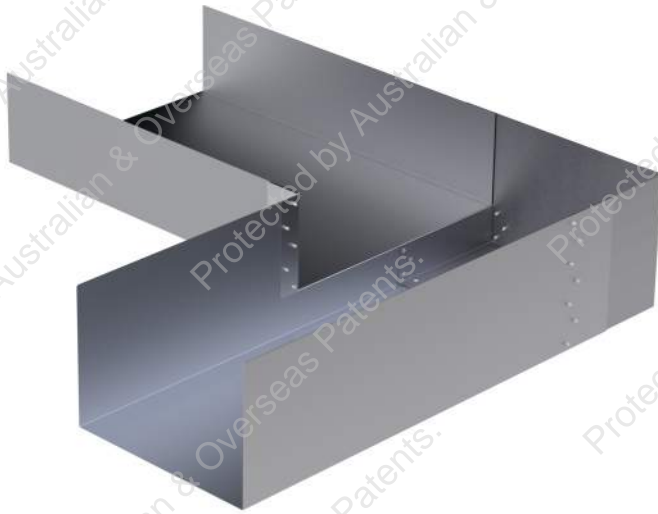

Dam Buster Elbow

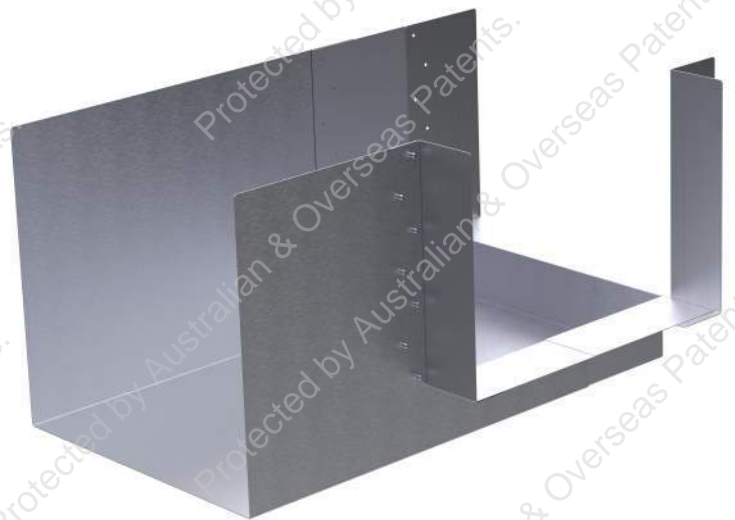

Dam Buster Corner Junction

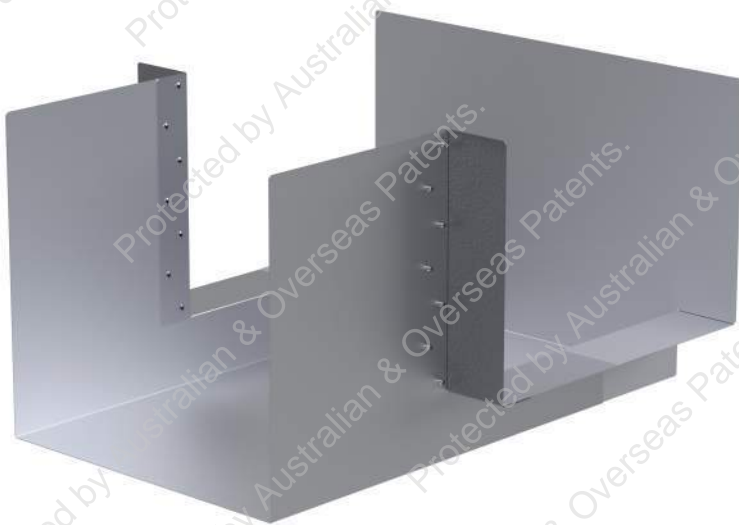

Dam Buster T Junction

Safety Information

Safety Warning

Sheet metal products by their nature may contain sharp edges which may cut on contact. Therefore, appropriate PPE including the wearing of appropriately graded anti-cut gloves, eye protection and suitably protective clothing and footwear is recommended during handling of the Dam Buster product range.



Disclaimer

Dam Buster provides a range of high performance, standardized and conforming products which can provide some element of customisation as allowed for within the Product Technical Statement, this Installation Manual and other Dam Buster guidance material. If any particular installation does not fall within these clear guidelines, the certifying plumber (or other relevant person) needs to ensure full compliance is still achieved in accordance with all applicable codes and standards relevant to the location of installation.

1.0 Installation Instructions for Dam Buster Rainhead

1.1 Installation method options for the Dam Buster Rainhead

There are a number of ways to install a Dam Buster rainhead, and the most appropriate method depends on the installer's preferences, the products purchased, and the specific project details. These methods are summarized as below, and installation instructions are provided in sections 1.2 to 1.5.

NOTE

For some situations it may be appropriate to use a 'stretched' rainhead, which has a greater width (in the direction parallel to the parapet wall). For example, an R-300-450 rainhead is a standard R-300 rainhead which has been 'stretched' to fit a 450mm box gutter. Stretched rainheads do not have a greater hydraulic capacity, so in this example, the rainhead is sized as for an R-300 rainhead. The installation requirements for a stretched rainhead are no different to the 'unstretched' rainhead. An adjustable Dam Buster Box Gutter Adaptor is also available to suit all 'stretched' rainheads so as to provide a proprietary seal for connection to box gutter.

Method 1 – Standard width box gutter to a rainhead with a box gutter receiver

- This method involves fitting a standard width box gutter to a Dam Buster rainhead including a factory installed box gutter receiver.
- 'Standard' box gutter widths are 200mm, 300mm, 400mm, 500mm & 600mm.
- The inbuilt box gutter receiver is slightly wider than the standard width. For example, the box gutter receiver for a 200mm wide box gutter is 203mm wide.

Method 2 – Non-standard width box gutter to a rainhead with a box gutter receiver

- This method involves fitting a non-standard width box gutter to a Dam Buster rainhead including a factory installed box gutter receiver.
- Installing a non-standard width box gutter to a rainhead with a box gutter receiver suited for a standard width box gutter results in a gap on one side of the gutter, which is required to be filled by the installer in a compliant manner.

Method 3 – Non-standard or standard width box gutter to a Flat Back rainhead

This method involves the usage of a Flat Back rainhead, which does not have a box gutter receiver. There are two methods for fitting a standard or non-standard width box gutter to a flat back rainhead, as follows:

- **Method 3A** – Use of the Dam Buster **Box Gutter Adaptor**
 - This is the preferred method and involves using the Dam Buster Box Gutter Adaptor, which can be requested from manufacturer to be supplied with a Flat Back Rainhead.
- **Method 3B** – Fashioning the back plate to receive the box gutter.
 - This is an older method (prior to the introduction of the Box Gutter Adaptor) but is provided for completeness.

1.0 Installation Instructions for Dam Buster Rainhead (cont.)

1.2 Installation Method 1 and common instructions for each installation method

This section provides the installation details for Method 1, most of which are common to the other installation methods. Sections 1.3 to 1.5 provide information which is specific to the other installation methods.

IMPORTANT NOTE: Before proceeding you must always correctly select the Dam Buster Rainhead to suit the design flow rate in litres / sec for the roof catchment area. Refer to the Dam Buster **Product Technical Statement** for roof catchment area calculations and rainhead/downpipe flow capacities.

YOU WILL NEED:

- 4-2 or 4-1 size 3.2mm (1/8th) diameter 1.6 - 3.2mm grip appropriately corrosion resistant pop rivets (sealed rivets preferable and colour matched where required)
- Hand riveter or power riveter
- 3.2mm (1/8th inch) drill bit and small battery drill
- Silicone gun and 1 x tube of Roof & Gutter Silicone (colour matched)
- Left and right hand snips.
- Downpipe pop / nozzle to suit sizing requirement.
- 2 or 4 (depending on size of the downpipe pop/nozzle to suit sizing requirements) x appropriately corrosion resistant and UV stable wall fixings or screws (maximum 5.5mm in size)
- Spirit Level
- Clean rags
- Set Square
- Pencil

NOTE – MECHANICAL FASTENERS

Dam Buster recommends only rivets be used as the mechanical fasteners (i.e. not screws) for joining box gutters and installing Dam Buster devices. Rivets must always be installed such that the heads of the rivets are flush with the inner surface (water face) of the box gutter. Cover rivet head with silicone.

See Diagram A showing section of the installed Dam Buster Rainhead and box gutter for overview of installation.

1. Where the box gutter exits the wall of the building, the end of the box gutter should either be cut flush with the outside cladding face of the building or protrude no more than 25mm from the outside cladding face of the building. If the latter, measure a maximum of 25mm and neatly cut a small “V” shape in the corners at the base of each side of the box gutter using left and right-handed snips and DO NOT bend the cut tab downwards yet.

1.0 Installation Instructions for Dam Buster Rainhead (cont.)

1.2 Installation Method 1 and common instructions for each installation method (cont.)

DIAGRAM 'A'

SECTION THROUGH INSTALLED DAM BUSTER RAINHEAD & BOX GUTTER

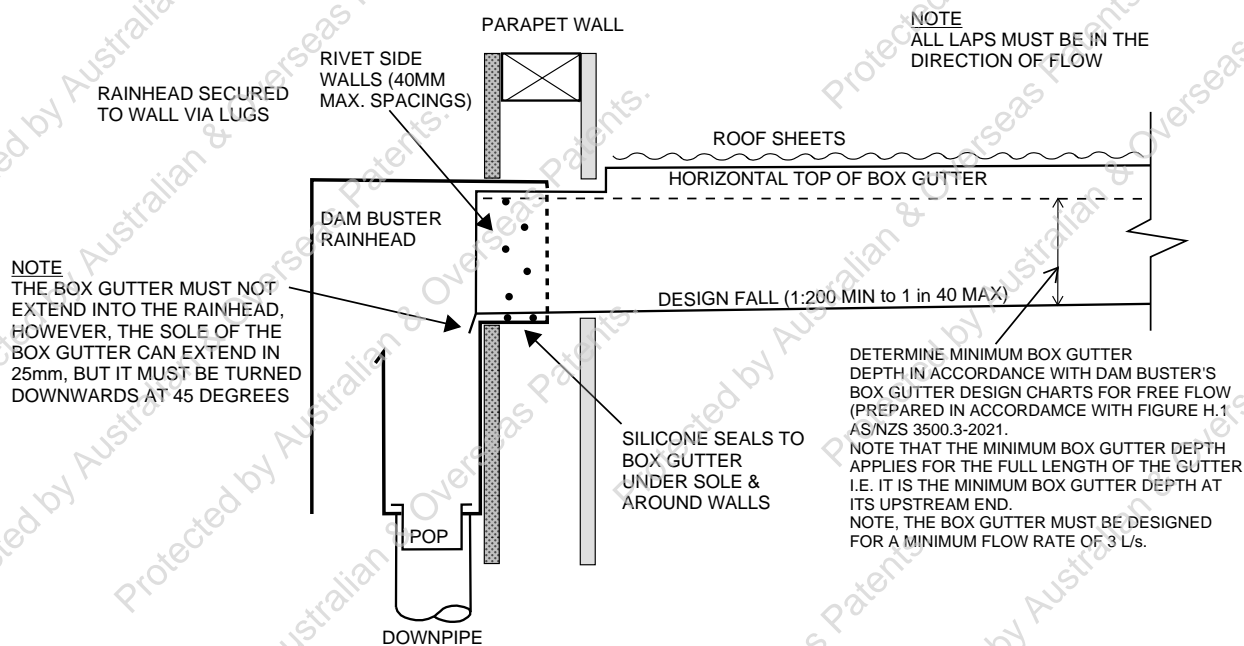

2. Dry test the Dam Buster Rainhead to ensure that the rear seal slides easily under the sole of the box gutter and that the Dam Buster Rainhead fits snugly to the wall of the building and the box gutter.
3. Once the downpipe size has been selected / designed neatly cut and rivet a downpipe pop / nozzle into the base of the Dam Buster Rainhead to suit the downpipe size, shape, position and off-set. Use colour-matched Roof & Gutter Silicone to seal the downpipe pop / nozzle.
4. Carefully and thoroughly apply colour-matched Roof & Gutter Silicone to seal all of the internal seams and rivet fixings on the inside of the Dam Buster Rainhead, including the open seam on both sides which is directly beneath the main overflow weir, facing the external facade.

Note: Dam Buster Rainheads are supplied as pre-siliconed between the lap joins, however, the installing roof plumber must still apply silicone to the seams and rivets at the time of installation. The licenced installing plumber is responsible for ensuring a water tight finish to the installed device.

1.0 Installation Instructions for Dam Buster Rainhead (cont.)

1.2 Installation Method 1 and common instructions for each installation method (cont.)

5. Apply 2 x generous beads of Roof & Gutter Silicone across the rear of the Dam Buster Rainhead on top of the base of the box gutter seal and also down the internal sides of the box gutter seal. Optionally, silicone can also be applied on the outside of the rear of the Dam Buster Rainhead and box gutter seal. The silicone will act as a seal to the area around the outside of the box gutter wall junction when the Dam Buster Rainhead is pressed against the wall of the building (much like a cover plate).
6. Refer Diagram B showing connection of Dam Buster Rainhead to the box gutter.
7. Carefully insert the Dam Buster Rainhead under the box gutter.

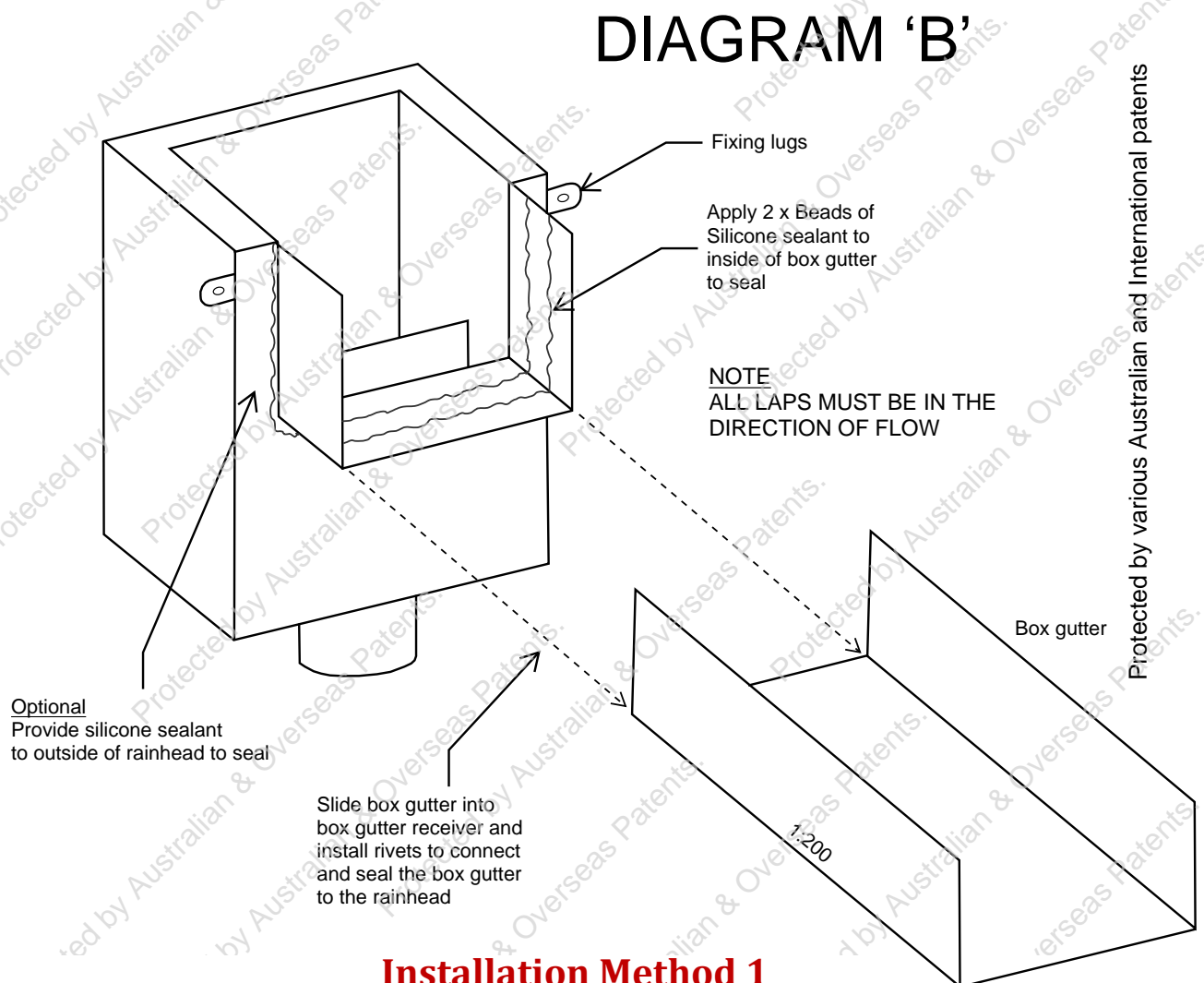

Installation Method 1

Connection of a standard width box gutter to rainhead with factory installed box gutter receiver

1.0 Installation Instructions for Dam Buster Rainhead (cont.)

1.2 Installation Method 1 and common instructions for each installation method (cont.)

NOTE: The box gutter fits directly into the Dam Buster Rainhead. The gutter seal receiver on the Dam Buster Rainhead is sized slightly larger to facilitate this. Do NOT attempt to fit the Dam Buster Rainhead into the box gutter.

8. Drill 3.2mm (1/8th inch) diameter rivet holes at 40mm spacings (staggered pattern) into each of the side wall of the box gutter, also penetrating the seal on the Dam Buster Rainhead. Insert and fix corrosion resistant rivets (preferably sealed type) at 40mm centres and staggered, on each side wall.
9. Drill and pop rivet the sole of the box gutter to fix and seal to the gutter receiver with 40mm spacings (staggered pattern). Carefully seal each rivet with Roof & Gutter silicone and wipe away any metal swarf from within the box gutter and Dam Buster Rainhead.
10. Fix the Dam Buster Rainhead to the wall via the external lugs on both sides – ensuring that the Dam Buster Rainhead is installed level with use of a spirit level. Use appropriately corrosion resistant and UV stable fixings of sufficient strength to ensure adequate attachment to the building.
11. Note that the box gutter should NOT extend into the rainhead as this will impact the outflow nappe (i.e. the curve of the water shedding off the end of the box gutter chute where it drops into the rainhead), however, the sole of the box gutter can extend in 25mm if it is turned downwards by a minimum of 45 degrees, as shown in Diagram A, as this will ensure no impact on the nappe.
12. Fit and fix the downpipe into the downpipe pop / nozzle with appropriately corrosion resistant rivets. Ensure downpipe is appropriately saddled along its entire length in compliance with the requirements of AS/NZS 3500.3 & SA HB39 (Vic/Tas only).
13. A Chute Lid can be ordered as an extra component for installing within the parapet wall of a straight box gutter to prevent vermin entry. To install, the Chute Lid is in the form of a U-shaped piece of sheet metal with pre-drilled holes for fixing. This should be lifted up to fit neatly and tightly within the parapet wall section and cut and folded to provide a seal with any flashings or parapet cappings.

Note:

The Chute Lid should be lifted up to the point where it is in line with the top of the rainhead where it passes through the parapet wall (i.e., minimum height 150mm)

2.0 Installation Instructions for Dam Buster Rainhead (cont.)

1.2 Installation Method 1 and common instructions for each installation method (cont.)

14. Advise Property Owners of the requirement of Australian Standards (AS/NZS 3500.3; Section 3.2, NOTE 3, and Clause M.5, Appendix M) for the regular maintenance of the roof drainage system (i.e. cleaning of any accumulated debris from the box gutter and rainhead on a regular basis). Educate Property Owner regarding the 'visual alert' of the operation of the Dam Buster Rainhead overflow indicating that there is a blockage requiring clearing.

15. Note that installation of the curve fronted rainhead is identical to that for the standard rectangular rainhead.

IMPORTANT NOTE: It is the licensed roof plumber's responsibility to certify all works associated with the installation of the box gutters and Dam Buster devices in accordance with the specific requirements of that State or Territory.

1.0 Installation Instructions for Dam Buster Rainhead (cont.)

1.3 Installation Method 2 - Non-standard width box gutter to a rainhead with a factory installed box gutter receiver.

Below are additional installation instructions for fitting a non-standard width box gutter to a rainhead with a factory installed box gutter receiver.

1. Where the box gutter sizing does not exactly match the proprietary width of the Dam Buster Rainhead (i.e., the box gutter width is smaller), the roof plumber can fold up and install their own filler section so long as the alterations comply with the requirements of AS/NZS 3500.3 and SA HB39 (Vic & Tas only). Refer to Diagram C for this installation method.

DIAGRAM 'C'

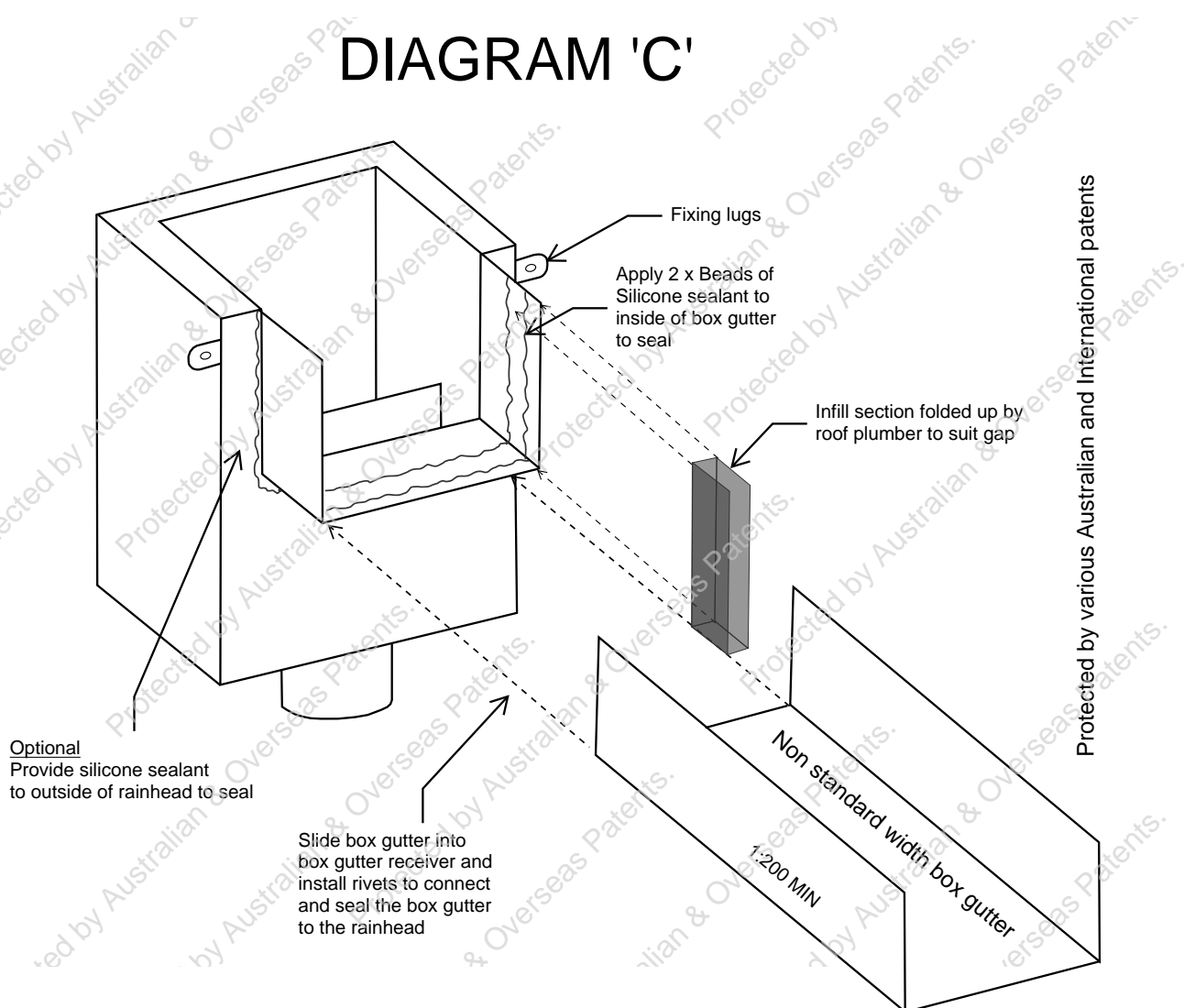

Installation Method 2

Installation of a non-standard width box gutter to rainhead with factory installed box gutter receiver.

1.0 Installation Instructions for Dam Buster Rainhead (cont.)

1.4 Installation Methods 3A & 3B for Flat Back rainheads

Standard and non-standard width box gutters can be fitted to a Flat Back rainhead using Methods 3A or 3B.

Method 3A – Use of the Dam Buster Box Gutter Adaptor

There are three box gutter adaptor sizes, as follows:

- | | |
|--------------------|--|
| BGA-200-300 | This adaptor suits box gutters with widths in the range 200mm to 300mm |
| BGA-300-500 | This adaptor suits box gutters with widths in the range 300mm to 500mm |
| BGA-400-600 | This adaptor suits box gutters with widths in the range 400mm to 600mm and is also height adjustable to suit Dam Buster rainheads of 400, 500 or 600 sizing. |

Method 3A – Installation Instructions

The following specific instructions for Method 3A should be read in conjunction with the 'Common Installation Instructions' in section 1.2, and where relevant, take precedence over the 'Common installation instructions'.

- (1) Check and measure the width of the box gutter that the adaptor is to be fitted around. Note that if the adaptor is being used at its full width, then the tabs on either side of the adaptor will need to be cut off (otherwise, leave them in place).

Note: For BGA-400-600, the adaptor will also need to be trimmed down in height for use with Dam Buster 400 or 500 rainhead sizes. There are notch guides on sides of adaptor which match heights of 400 and 500 rainheads.
- (2) Assemble the adaptor so that it is 3mm wider than the internal measurement of the box gutter to which it is to be fitted. Rivet the adaptor together using the pre-drilled holes which are at the required spacings.
- (3) Use the assembled adaptor as a template to then mark with pencil the area to be cut at the rear of the flat back panel of the rainhead. Note that there is a crease fold which identifies the location of the sole of the box gutter on the rear flat back panel which ensures that a minimum 25mm height differential is maintained between the sole of the box gutter and the overflow weir of the rainhead. **Never cut below this crease line.**
- (4) Neatly cut out the rear panel of the flat back rainhead using snips.

1.0 Installation Instructions for Dam Buster Rainhead (cont.)

Method 3A – Installation Instructions

- (5) Dry fit the adaptor and drill holes for rivets. To hold the adaptor in place during this process, vice grips should be utilised. Note rivet spacings of 40mm intervals are required.
- (6) Neatly apply an appropriate bead of silicone sealant within the lap joint between the adaptor and rainhead. Install rivets. Clean off any excess silicone.

DIAGRAM 'D'

Protected by various Australian and International patents

Tabs on one or both sides of the adaptor need to be trimmed off if it is being used at (or near) the full width (otherwise they should be left intact).

Install adaptor such that the top of the horizontal pieces aligns with the horizontal crease line in the back of the rainhead (which is located 25mm higher than the top of the internal weir).

Dam Buster Box Gutter Adaptor comprising 2 sliding / overlapping pieces, which allow for any box gutter width in the adaptor width range.

NOTE
For BGA-400-600 sizes, the height of the adaptor will also need to be trimmed to suit the height of the Dam Buster Rainhead. Notches on the side of the adaptor indicate the trim down height for 400 and 500 rainheads

NOTE
All lapped surfaces should be joined with rivets at 40mm maximum spacings, with silicone sandwiched between the laps.

Cut penetration in rear of Flat Back Rainhead to suit Dam Buster Box Gutter Receiver and Box Gutter. Refer to 'Cut-Out' dimensions below.

Vertically align Flat Back Rainhead such that the top of the internal weir is 25mm lower than the sole of the box gutter. Refer also note regarding the crease line in the back of the rainhead

25mm

1:200 MIN

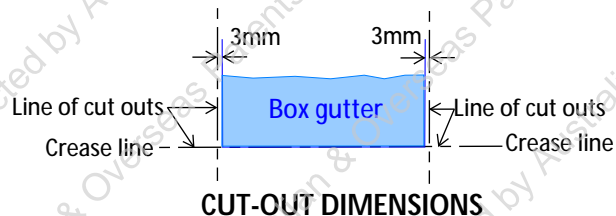

Installation Method 3A

Installation of a standard or non-standard width box gutter to a Flat Back Rainhead using the Dam Buster Box Gutter Adaptor

1.0 Installation Instructions for Dam Buster Rainhead (cont.)

Method 3B – Fashioning a Flat Back rainhead to receive a box gutter.

Refer to diagram E below. Where this method is adopted, it is the responsibility of the installing plumber to ensure a compliant seal is made between the box gutter and the rainhead, however, the following information is provided for guidance should the installing plumber adopt this method. Note that Dam Buster recommends the seal between the box gutter and the rainhead be made using either a rainhead with a factory installed box gutter receiver or the Dam Buster Box Gutter Adaptor.

For this method, the back plate of a standard or non-standard width box gutter is fashioned by the roof plumber to receive the box gutter. The connection must be made with a 20mm to 25mm lap joint and mechanically fastened at no more than 40mm centres, in accordance with AS/NZS 3500.3 and SA HB 39 (where applicable). The rainhead must be vertically aligned such that the top of the internal weir is 25mm below the sole of the box gutter. Note that there is a horizontal crease on the back of the rainhead which is located 25mm above the top of the weir to assist with the installation.

Method 3B – Installation Instructions

The following specific instructions for Method 3B should be read in conjunction with the '*Common Installation Instructions*' in section 1.2, and where relevant, take precedence over the '*Common installation instructions*'.

- (1) Check and measure the width of the box gutter that is to be connected to.
- (2) Using a pencil and ruler, draw the outline of the end of the box gutter onto the rear of the flat back panel of the rainhead, allowing a 3 - 5mm larger width size than the measured box gutter size.
- (3) The crease fold line on the back of the flat back rainhead defines the sole height of the box gutter. The sole of the box gutter must end up in line with this crease fold to safeguard the height differential of 25mm between the sole of the box gutter and the overflow weir of the rainhead.
- (4) A 25mm lap fold will be required to all 3 sides of the cut out and should be drawn onto the rear panel prior to any cutting.
- (5) Cut out the flat back panel to the required size and fold the laps out to the rear of the rainhead.
- (6) Fit the rainhead to the box gutter and silicone and rivet the lap joints at 40mm spacings with silicone sandwiched between the laps. Ensure that the corners are well silicone sealed and that the box gutter is folded down into the rainhead at a 45-degree angle and overhangs into the rainhead by no more than 25mm.

1.0 Installation Instructions for Dam Buster Rainhead (cont.)

Method 3B – Installation Instructions

DIAGRAM 'E'

Protected by various Australian and international patents

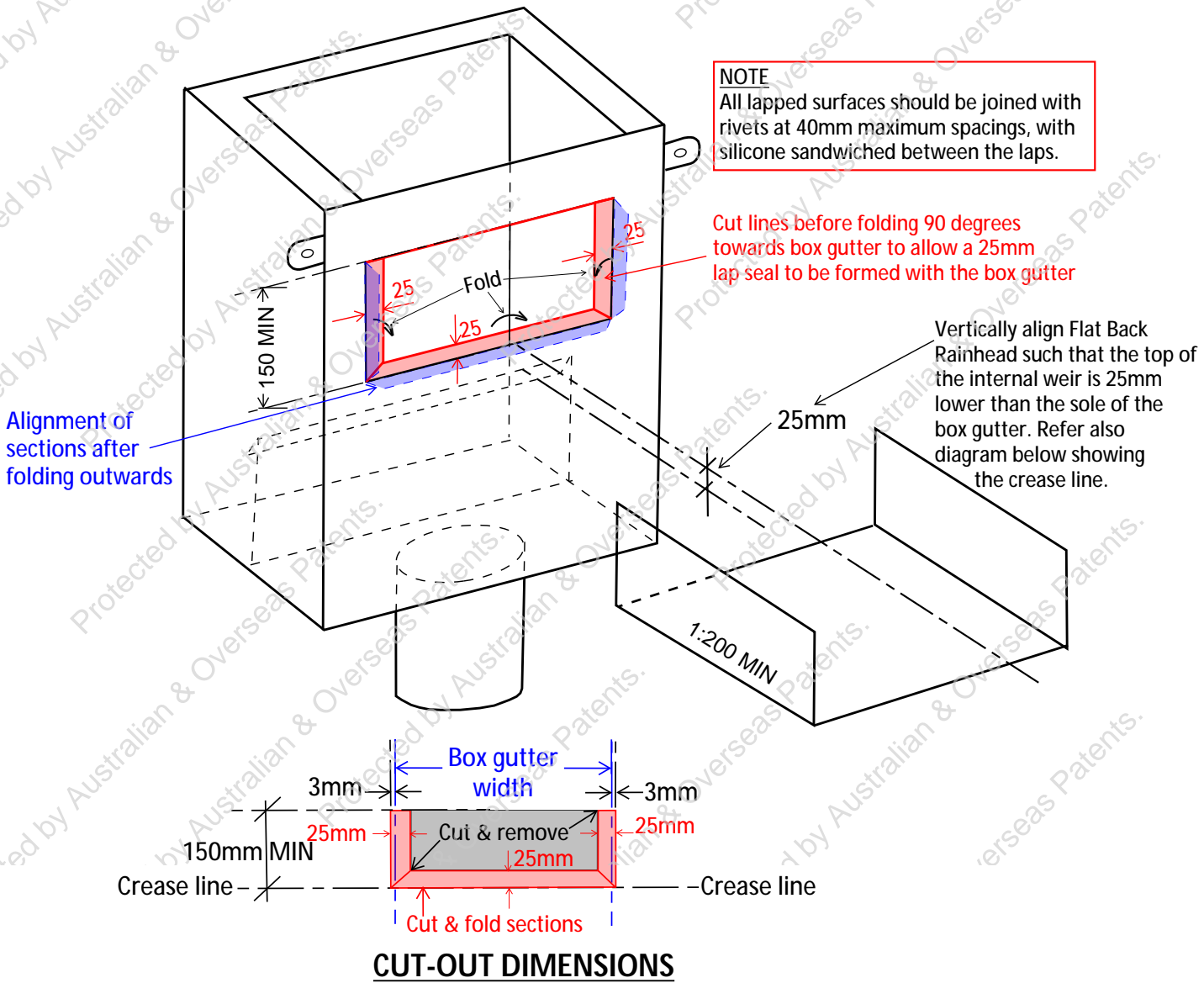

Installation Method 3B

Fashioning the back plate of a Flat Back Rainhead to install a standard or non-standard width box gutter.

1.0 Installation Instructions for Dam Buster Rainhead (cont.)

1.5 Installation of eaves gutters to a Flat Back Rainhead

Refer to diagram F below. When using a Flat Back Dam Buster Rainhead for an eaves gutter application, the eaves gutter profile will need to be carefully and neatly marked and scribed onto one or both sides of the rainhead. These scribed profiles can then be cut out to allow the effective drainage of the eaves gutter to pass through the side walls of the rainhead and discharge within the rainhead. The sole of the eaves gutter should be positioned at least 25mm higher than the weir overflow. We note that whilst there is reference within the NCC for the use of rainheads in eaves gutter applications, there is no reference to this within AS/NZS 3500.3 and therefore the use of rainheads does not void the requirement for a continuous overflow provision at the rear of high fronted eaves guttering and the eaves guttering must still be installed in accordance with the requirements of AS/NZS 3500.3 and any manufacturer's guidelines.

DIAGRAM 'F'

Profile cut eaves gutter and extend 10mm into rainhead. Provide silicone sealant.

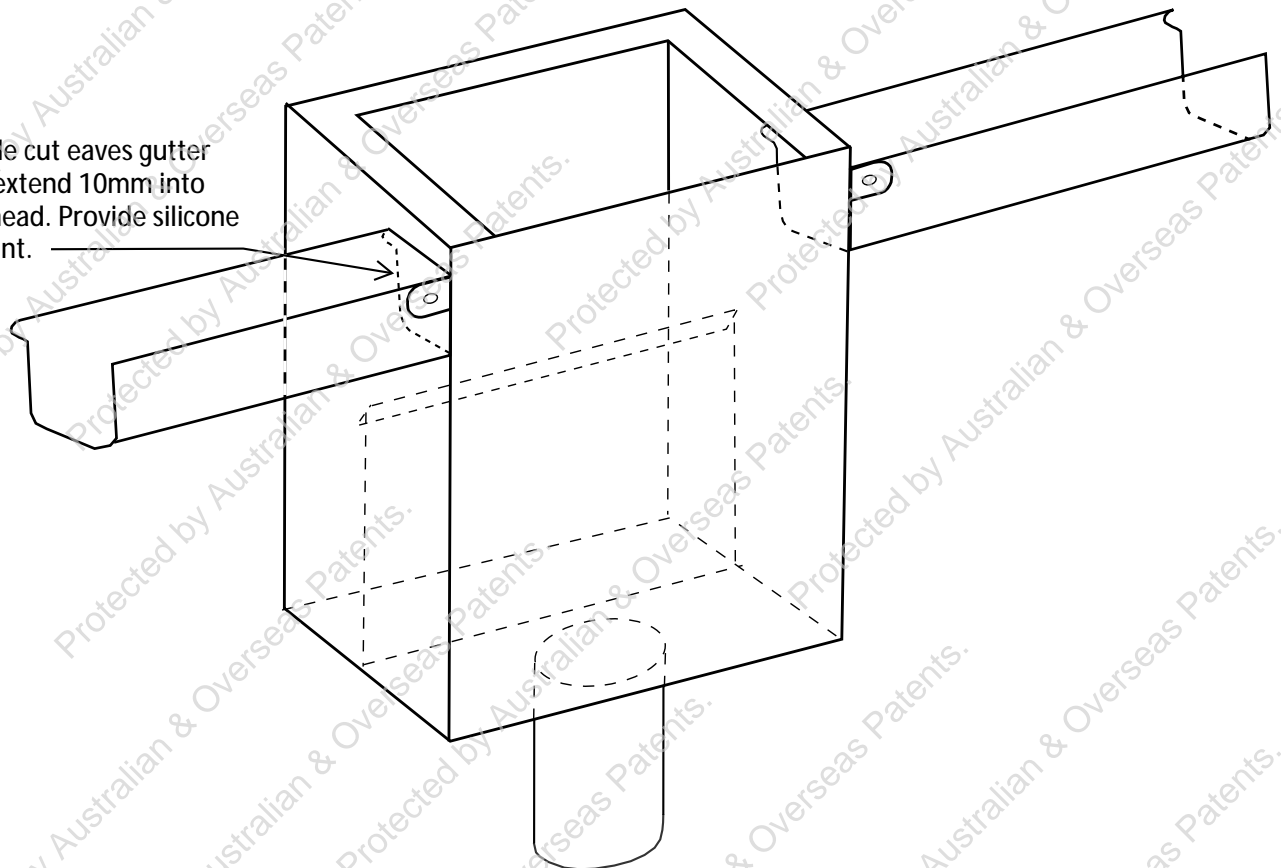

Connection of Eaves Gutters to a Dam Buster Flat Back Rainhead

2.0 Installation Instructions for Dam Buster Side Outlet* and Rainhead combination

* All versions- T Side Outlet, End Side Outlet, Corner Side Outlet & Cruciform Side Outlet.

- 2.1 Installation instructions are provided below for Dam Buster box gutter overflow device comprising a Dam Buster Side Outlet device and a Dam Buster Rainhead. Note that a Dam Buster Side Outlet may **only** be used in combination with a Dam Buster Rainhead or a fully compliant AS/NZS 3500.3 rainhead.

IMPORTANT NOTE: Before proceeding you must always correctly select the Dam Buster Rainhead and Side Outlet combination to suit the design flow rate in litres / sec for the roof catchment area. Refer to the Dam Buster **Product Technical Statement** for roof catchment area calculations and rainhead/downpipe flow capacities.

YOU WILL NEED:

- 4-2 or 4-1 size 3.2mm (1/8th) diameter 1.6 - 3.2mm grip appropriately corrosion resistant pop rivets (sealed rivets preferable and colour matched where required)
- Hand riveter or power riveter
- 3.2mm (1/8th inch) drill bit and small battery drill
- Silicone gun and 1 x tube of Roof & Gutter Silicone (colour matched)
- Left and right hand snips.
- Downpipe pop / nozzle to suit sizing requirement.
- 2 or 4 (depending on size of the downpipe pop/nozzle to suit sizing requirements) x appropriately corrosion resistant and UV stable wall fixings or screws (maximum 5.5mm in size)
- Spirit Level
- Clean rags
- Set Square
- Pencil

NOTE – MECHANICAL FASTENERS

Dam Buster recommends only rivets be used as the mechanical fasteners (i.e. not screws) for joining box gutters and installing Dam Buster devices. Rivets must always be installed such that the heads of the rivets are flush with the inner surface (water face) of the box gutter. Cover rivet head with silicone.

1. Measure the width of the box gutter(s) that will be entering the Dam Buster Side Outlet. Select the appropriate Side Outlet configuration that will adjust to suit the box gutter width. Ensure that the flow rate for the corresponding Dam Buster Rainhead and downpipe combination is not exceeded by the combined box gutter in-flow.

Dam Buster Side Outlet configuration options:

- Dam Buster T Side Outlet (see Diagram 1)
- Dam Buster End Side Outlet (RH or LH) (see Diagram 2)
- Dam Buster Corner Side Outlet (RH or LH) (see Diagram 3)
- Dam Buster Cruciform Side Outlet (see Diagram 4)

2.0 Installation Instructions for Dam Buster Side Outlet and Rainhead combination (cont.)

Dam Buster Side Outlet sizes for box gutter widths:

- **SO-200 Side Outlet** – adjusts to suit box gutters from **200mm to 350mm** in width. Requires **R-200 or CR-200 Rainhead** combination.
- **SO-300 Side Outlet** – adjusts to suit box gutters from **300mm to 450mm** in width. Requires **R-300 or CR-300 Rainhead** combination. Note: At lower flow rates not exceeding 5.0 L/s, an R-200-300 stretched rainhead could be otherwise utilised.
- **SO-400 Side Outlet** – adjusts to suit box gutters from **400mm to 600mm** in width. Requires **R-400 or CR-400 Rainhead** combination. At lower flow rates of less than 9.6L/sec, an R-300-400 'stretched' could otherwise be utilised.

- **IMPORTANT NOTE**

The Side Outlet device **MUST NOT** be used outside the above noted ranges (unless a site-specific design is prepared under a Performance Solution by a suitably qualified hydraulic engineer). However, there should generally be no need to use Side Outlets for box gutter widths other than those specified above which include all allowable widths in accordance with AS/NZS 3500.3 i.e. between 200mm to 600mm.

2. Dam Buster Side Outlets can either be installed prior to a box gutter installation (preferable) or, if required, they can be retrofitted into an existing box gutter installation.

***NOTE:** If retrofitting of the Dam Buster Side Outlet is a necessity, then extra care is required in relation to the riveting and sealing of the connection between the existing box gutter and the Dam Buster Side Outlet device. Refer to **Diagram 6** for a recommended retrofitting method, which involves the usage of an additional 'stub box gutter' to assist with the installation process.*

3. The roof carpentry structure must provide adequate support for both the box gutter and the Dam Buster Side Outlet device. The Dam Buster Side Outlet has in-built gradient of 1:200 which equates to 5mm over 1m and this needs to be accommodated by the carpentry support structure through to the outside edge of the parapet wall. The support structure in contact with the box gutter must also be of a compatible material with the box gutter

***NOTE:** Some small amount of adjustment may be required to the roof carpentry support structure when fitting the adjustable component of the Dam Buster Side Outlet to ensure it sits neatly and maintains the 1:200mm gradient. Therefore, dry fitting of the product prior to final installation is highly recommended.*

2.0 Installation Instructions for Dam Buster Side Outlet and Rainhead combination (cont.)

4. The downstream section of the Dam Buster Side Outlet should be installed first. This is the portion that passes through the parapet wall and connects with the Dam Buster Rainhead, and comprises a 'short, deep box gutter' commencing at the open-ended sump. Depending on the Dam Buster Side Outlet configuration selected, there are gussets which need to be siliconed between the laps and then riveted. Note, the standard length of the 'short, deep box gutter' (beyond the open-ended sump) is 400mm. If necessary (for wide parapet walls) this can be extended with an additional box gutter section (of the same size) up to a maximum total length of 1,200mm.
5. The upstream section of the Dam Buster Side Outlet can then be installed. This is the portion which sits wholly within the open-ended sump portion of the device. It is recommended that the upstream section is dry fitted and marked in position with a pencil onto the downstream section of the device to ensure a neat and tidy fit. Silicone is then applied to the lapped portion of the downstream section of the device and the upstream section can then be fitted and riveted using the pre-drilled staggered rivet formation.
6. The Chute Lid component of the Dam Buster Side Outlet can now be fitted into the parapet wall to prevent vermin entry. This is in the form of a U-shaped piece of sheet metal with pre-drilled holes for fixing. This should be lifted-up to fit neatly and tightly within the parapet wall section and cut and folded to provide a seal with any flashings or parapet cappings. The Chute Lid has 4 x vertical windows so that one of these windows lines up with the product ID nameplate of the Side Outlet for ease of viewing.
Note: The Chute Lid should be lifted up to the point where it is in line with the top of the Side Outlet device where it passes through the parapet wall (i.e., minimum height 200mm).
7. The Dam Buster Rainhead can now be fitted (or alternatively left to a later stage depending on the construction timeline). See Installation Instructions for Dam Buster Rainhead for further details.
8. Once the rainhead is ready to install, apply 2 x Roof & Gutter silicone beads on both the base and walls of the box gutter receiving seal component of the Dam Buster Side Outlet. The box gutter can then be lowered into position on top of this seal, with the end of the box gutter flush with the step (drop down) edge. There is no need to over-hang the box gutter into the sump space of the Dam Buster Side Outlet. It should finish flush with the step.
9. Rivets (preferably sealed type) at 40mm maximum intervals (in a staggered pattern) to be drilled and fixed into the base and side walls of the box gutter.

Note: The box gutter and Side Outlet must be free to expand/contract and therefore should not be fixed to the structure

2 Installation Instructions for Dam Buster Side Outlet and Rainhead combination (cont.)

10. All exposed rivet heads to be neatly and thoroughly covered by Roof & Gutter silicone (colour-matched).
11. If the depth of the box gutter(s) do not match the depth of the Side Outlet, it will be necessary to either trim the top of Side Outlet wall (if the Side Outlet is deeper than the box gutter) or add a flashing to the rear wall of the Side Outlet (if the box gutter(s) are deeper than the Side Outlet). Refer to Diagram 5 for details.
12. Advise Property Owners of the requirement of Australian Standards (AS/NZS 3500.3; Section 3.2, NOTE 3 and Clause M.5, Appendix M) for the regular maintenance of the roof drainage system (i.e. cleaning of any accumulated debris from the box gutter and rainhead on a regular basis). Educate Property Owner regarding the 'visual alert' of the operation of the Dam Buster Rainhead overflow indicating that there is a blockage requiring clearing.

NOTE: It is the licensed roof plumber's responsibility to certify all works associated with the installation of the box gutters and Dam Buster devices in accordance with the specific requirements of that State or Territory.

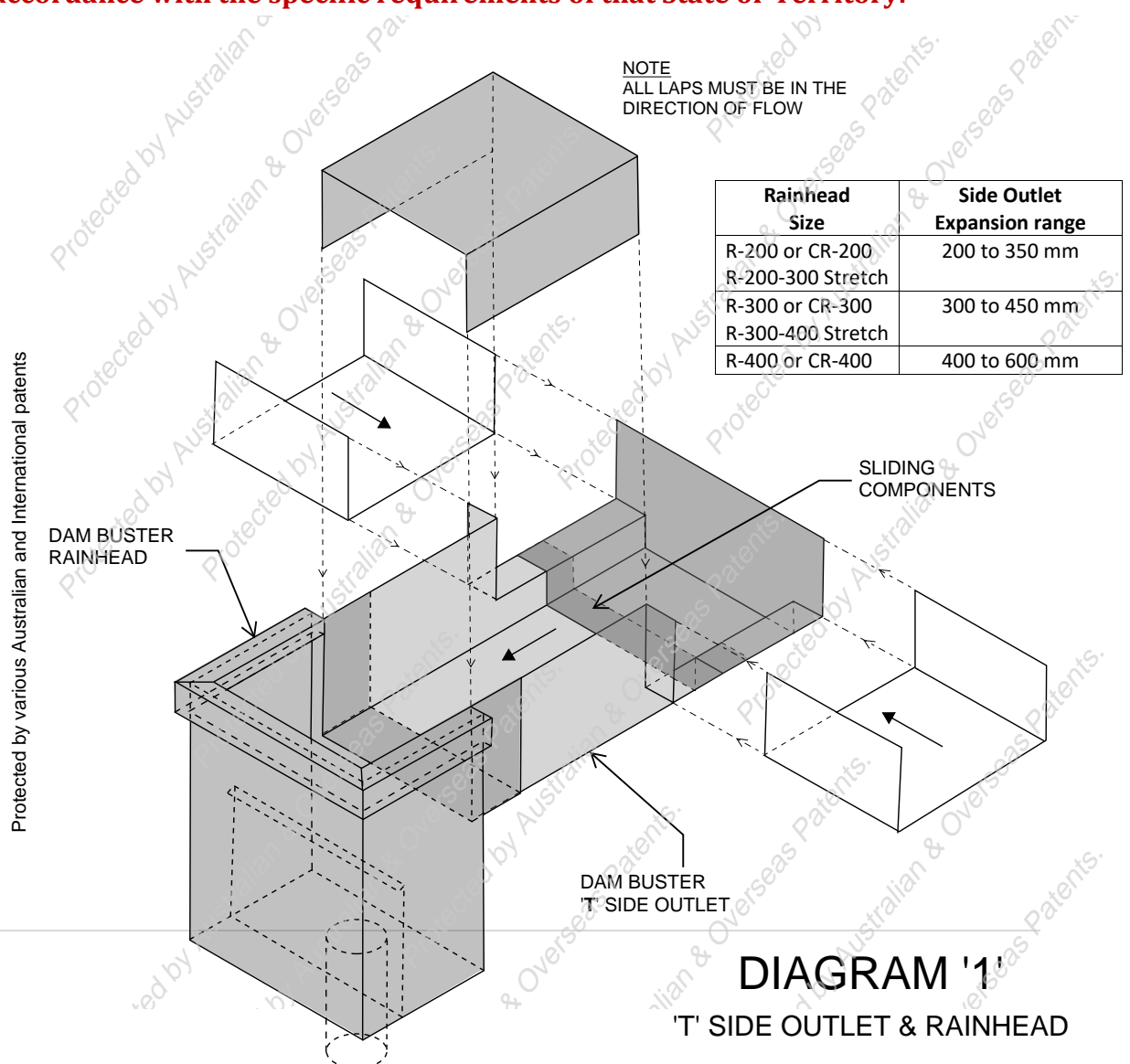

2.0 Installation Instructions for Dam Buster Side Outlet and Rainhead combination (cont.)

Rainhead Size	Side Outlet Expansion range
R-200 or CR-200 R-200-300 Stretch	200 to 350 mm
R-300 or CR-300 R-300-400 Stretch	300 to 450 mm
R-400 or CR-400	400 to 600 mm

Protected by various Australian and International patents

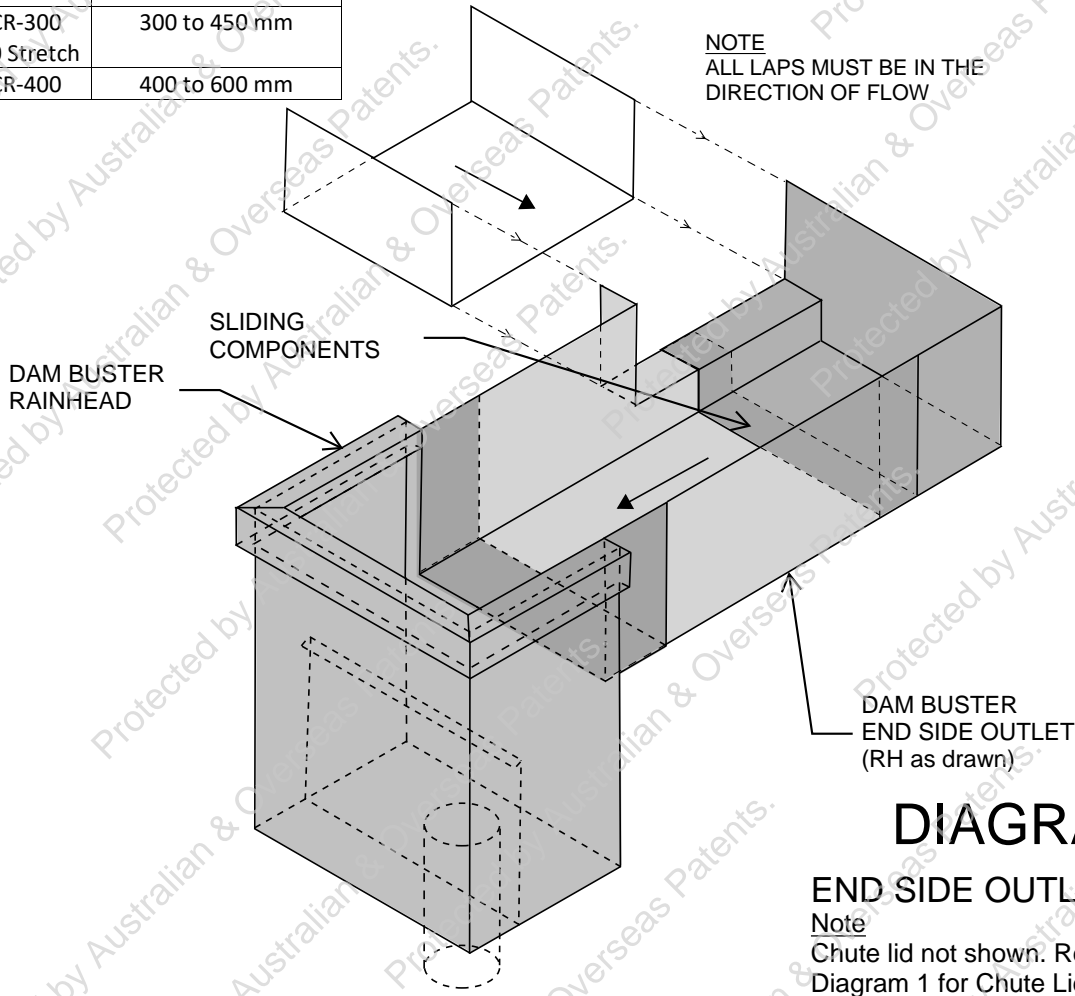

Is the device LH (Left Hand) or RH (Right Hand)?

The 'hand' is determined by viewing along the direction of flow.

For a RH device, the water 'turns' right at the device

For a LH device, the water 'turns' left at the device

Note – a RH version is shown in Diagram '2'.

2.0 Installation Instructions for Dam Buster Side Outlet and Rainhead combination (cont.)

Rainhead Size	Side Outlet Expansion range
R-200 or CR-200 R-200-300 Stretch	200 to 350 mm
R-300 or CR-300 R-300-400 Stretch	300 to 450 mm
R-400 or CR-400	400 to 600 mm

Rainhead Size	End box gutter size
R-200 or CR-200 R-200-300 Stretch	200 mm
R-300 or CR-300 R-300-400 Stretch	300 mm
R-400 or CR-400	400 mm

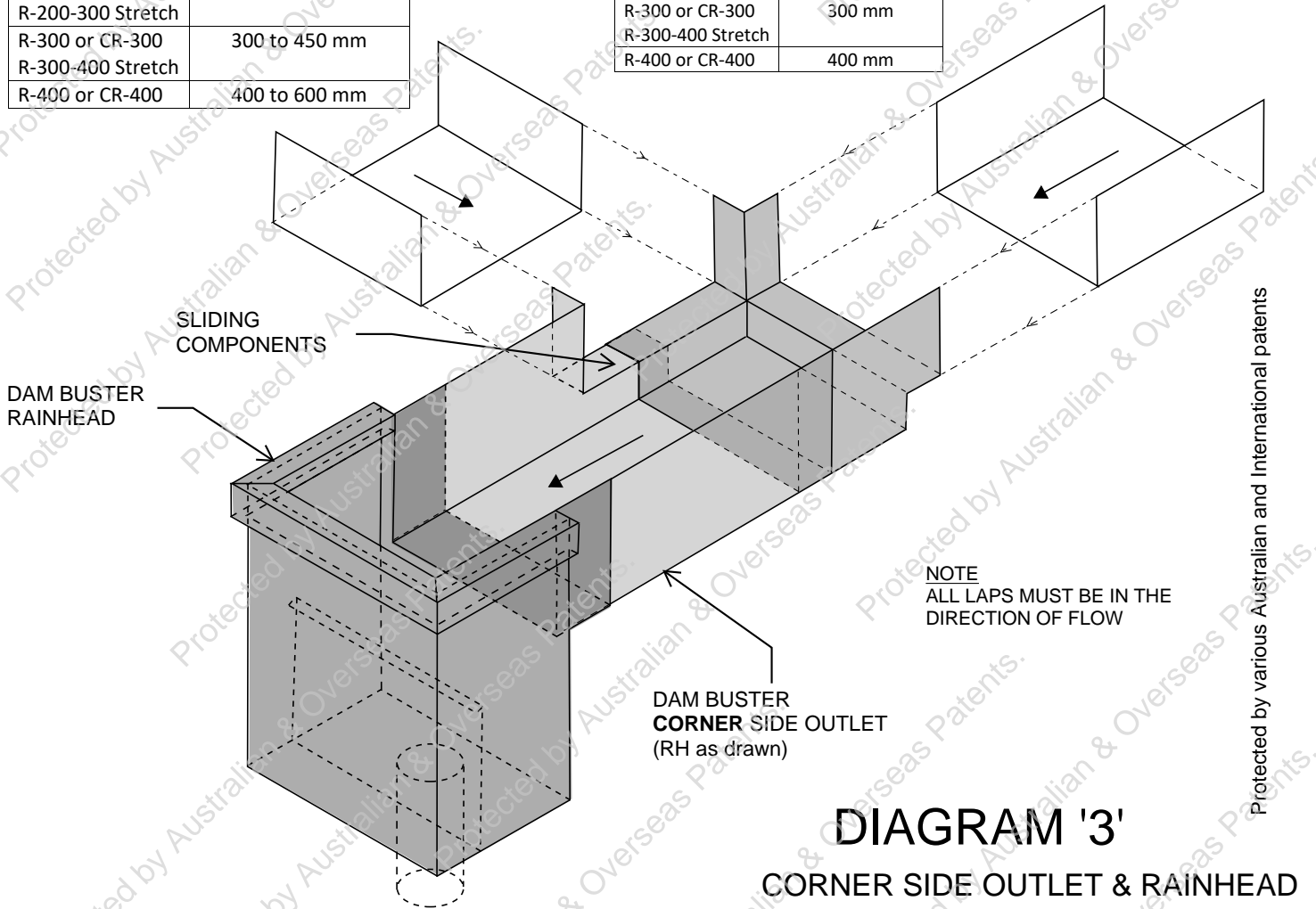

Note
Chute lid not shown. Refer to Diagram 1 for graphic.

Is the device LH (Left Hand) or RH (Right Hand)?

The 'hand' is determined by viewing along the direction of flow.

For a RH device, the water 'turns' right at the device

For a LH device, the water 'turns' left at the device.

Note – a RH version is shown in Diagram '3'.

2.0 Installation Instructions for Dam Buster Side Outlet and Rainhead combination (cont.)

Rainhead Size	Side Outlet Expansion range
R-200 or CR-200	200 to 350 mm
R-200-300 Stretch	200 to 350 mm
R-300 or CR-300	300 to 450 mm
R-300-400 Stretch	300 to 450 mm
R-400 or CR-400	400 to 600 mm

Rainhead Size	End box gutter size
R-200 or CR-200	200 mm
R-200-300 Stretch	200 mm
R-300 or CR-300	300 mm
R-300-400 Stretch	300 mm
R-400 or CR-400	400 mm

NOTE
ALL LAPS MUST BE IN THE DIRECTION OF FLOW

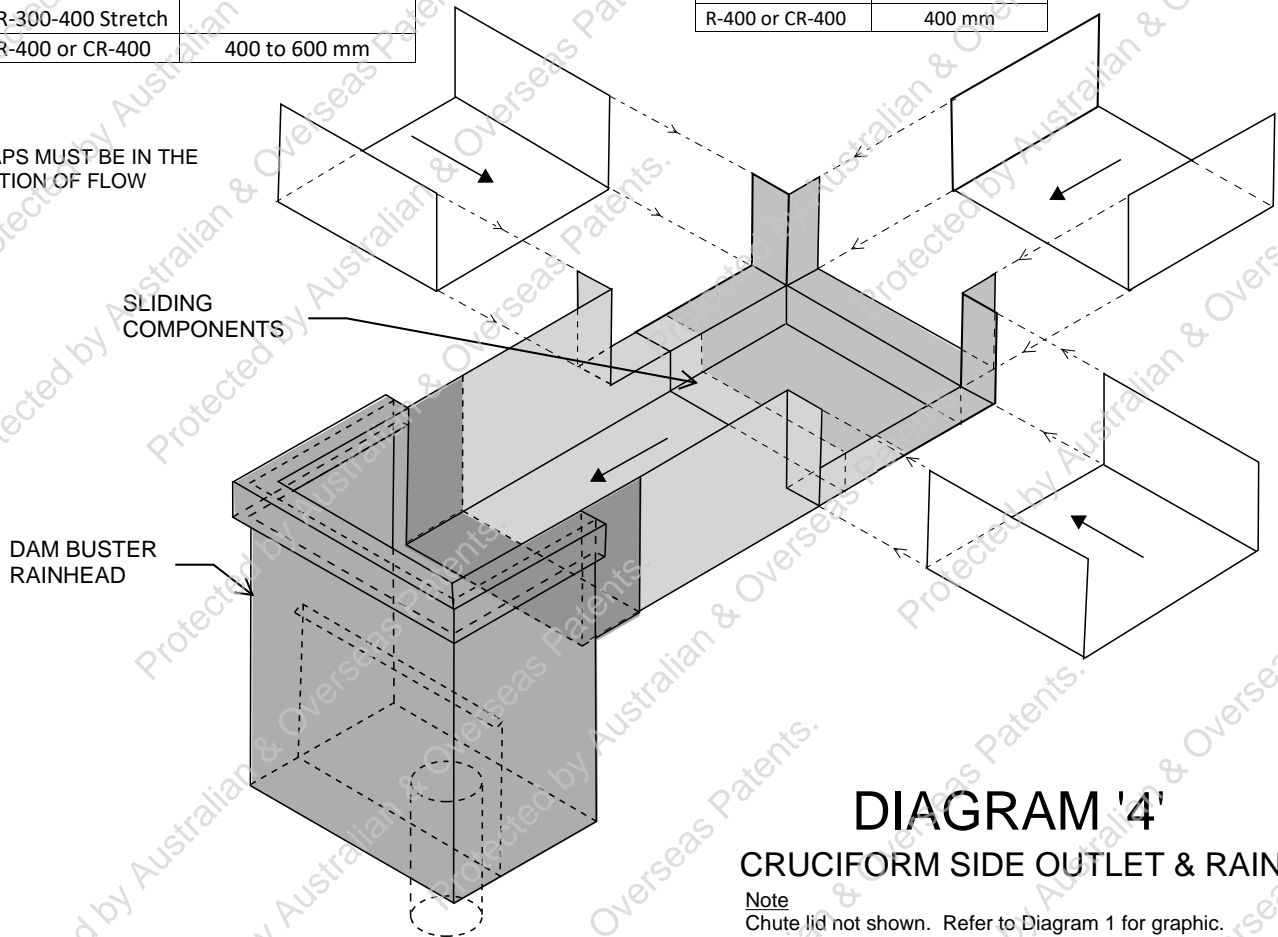

2.0 Installation Instructions for Dam Buster Side Outlet and Rainhead combination (cont.)

Note- the Side Outlet depth has been pre-engineered such that it is at least as deep as the minimum design (upstream) box gutter depth

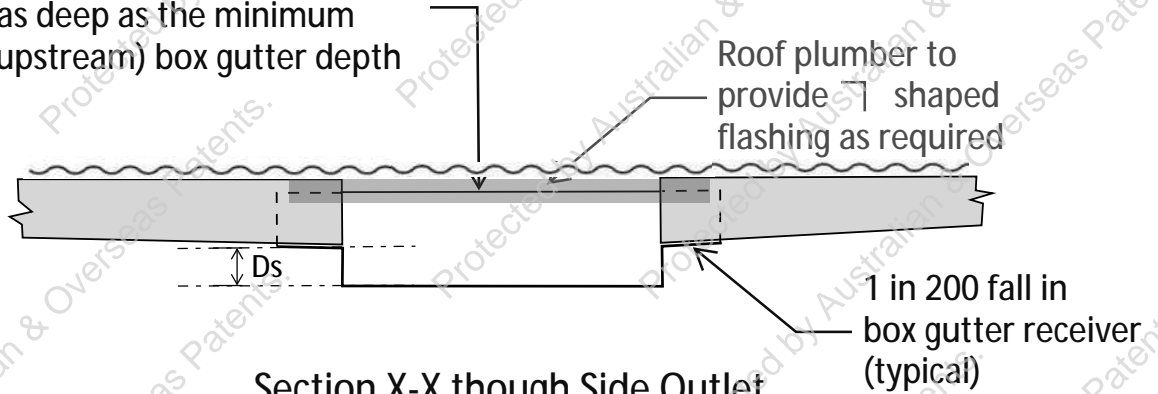

Section X-X through Side Outlet
Box gutter(s) deeper than Side Outlet

Rainhead size	Side Outlet Depth 'Ds'
DB200	40 mm
DB300	60 mm
DB400	70 mm

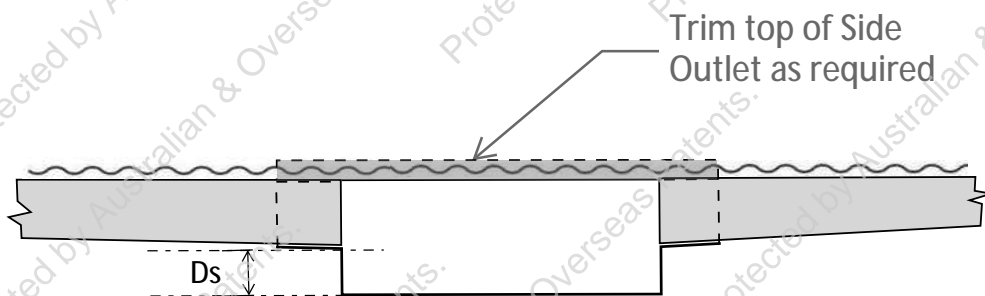

Section X-X through Side Outlet
Side Outlet deeper than Box gutter(s)

DIAGRAM '5'

CONNECTION OF BOX GUTTER(S) TO SIDE OUTLET

2.0 Installation Instructions for Dam Buster Side Outlet and Rainhead combination (cont.)

- Notes regarding requirements of AS/NZS 3500.3
1. Cl 4.5.4 *Box gutters* requires lap joints to be installed in accordance with Cl 4.5.3 (b)
 2. Clause 4.7.2.2 *Sealant* specifies requirements for sealants, which are to be sandwiched between clean surfaces of the components of the joint
 3. Cl 4.7.2.3 *Laps* require that fasteners be spaced at no more than 40mm centres, and not less than 10mm from the edges of the joint, and that laps are 25mm minimum wide
 4. Refer to AS/NZS 3500.3-2021 for further details.

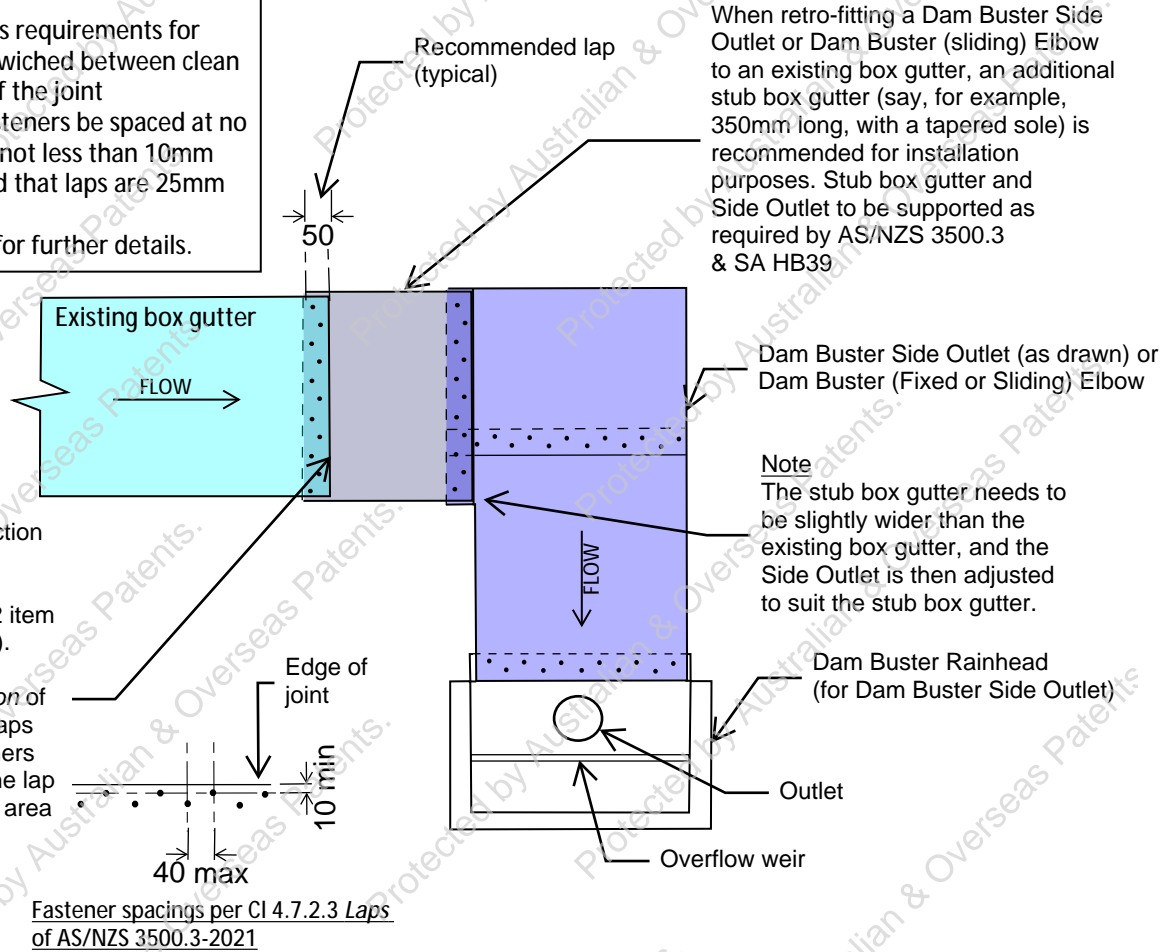

Retro-fitting the Dam Buster Side Outlet and the Dam Buster Elbow Plan View (NTS)

DIAGRAM '6'

RETROFITTING A DAM BUSTER SIDE OUTLET OR DAM BUSTER ELBOW

3.0 Installation Instructions for Dam Buster Sumps

3.1 Installation instructions are provided below for the Dam Buster Sumps.

IMPORTANT NOTE: Before proceeding you must always correctly select the Dam Buster Sump to suit the design flow rate in litres / sec for the roof catchment area. Refer to the Dam Buster **Product Technical Statement** for roof catchment area calculations and sump/downpipe flow capacities.

YOU WILL NEED:

- 4-2 or 4-1 size 3.2mm (1/8th) diameter 1.6 - 3.2mm grip appropriately corrosion resistant pop rivets (sealed rivets preferable and colour matched where required)
- Hand riveter or power riveter.
- 3.2mm (1/8th inch) drill bit and small battery drill
- Silicone gun and 1 x tube of Roof & Gutter Silicone (colour matched)
- Left and right hand snips.
- Downpipe pop / nozzle to suit sizing requirement.
- Spirit Level
- Clean rags
- Set Square
- Pencil

NOTE – MECHANICAL FASTENERS

Dam Buster recommends only rivets be used as the mechanical fasteners (i.e. not screws) for joining box gutters and installing Dam Buster devices. Rivets must always be installed such that the heads of the rivets are flush with the inner surface (water face) of the box gutter. Cover rivet head with silicone.

See Diagrams V, W, X, Y & Z showing installation of Dam Buster Sumps and box gutter.

- Diagrams V, W & X – Dam Buster Sumps
- Diagram Y – Dam Buster Back-to-Back Sumps
- Diagram Z – Dam Buster Continuous Sump

Note that the Continuous Sump arrangement has provision for an expansion joint (where necessary). The arrangement requires the supply of a separate box gutter receiver for each Dam Buster Sump in the 'internal' box gutter system. Note also, that where an expansion joint is required, it will be located at a 'high point' (i.e. 'upstream' end) within each box gutter, as required by SA HB39.

3.0 Installation Instructions for Dam Buster Sump (cont.)

1. Measure and neatly cut holes for the downpipe pops/nozzles in the base of the 2 x chambers of the Dam Buster Sump to suit the downpipe size, shape, position and off-set. Pre-drill rivet holes. Clean off all metal swarf.
2. Cut and install 2 x downpipe pops/nozzles with one in the first chamber and the other in the second chamber (for overflow pipe). Also, if using the full blockage overflow indicator (which is highly recommended, if installation situation allows) cut and install 90mm metal downpipe pop/nozzle ready to connect overflow blockage indicator in the wall of the Dam Buster Sump overflow chamber. Note that a PVC pipe which discharges at a visually obvious location will later need to be connected to this pop/nozzle to serve as the blockage indicator (with the centerline of this horizontal overflow pipe to be located at the same level as the sole of the box gutter).
3. The Dam Buster Sump should then be installed into the roof structure prior to the box gutter being installed and with the appropriate downpipe and overflow pop / nozzle outlets already installed into the Dam Buster Sump. However, the Dam Buster Sump should not be fixed to the structure so as to still allow for expansion / contraction.
4. The licenced installing plumber is responsible for ensuring a watertight finish to the installed device and therefore extra colour-matched Roof & Gutter Silicone should be applied to all seams, joints and rivets, as required, on site.
5. All pops/nozzles should then be carefully fitted, fixed and silicone sealed to the downpipe, overflow pipe and overflow blockage indicator pipe. Do NOT use long screws which will act to catch debris within pipe and cause blockages. The holistic and thorough sealing of the Dam Buster Sump to all connecting pipes is essential due to this being an internally located device.
6. The Dam Buster Sump needs to be well supported by the carpentry roof structure in the same manner in which box gutters need to be supported so that it is stable and unaffected by movement. However, the Dam Buster Sump should not be fixed to the structure so as to still allow for expansion / contraction.

3.0 Installation Instructions for Dam Buster Sump (cont.)

7. The box gutter can now be installed on top of the gutter receiver component on the Dam Buster Sump. Care should be taken to apply 2 x large beads of silicone across the base and up the walls of the gutter receiver component to achieve a holistic seal between the box gutter and the Dam Buster Sump. There is no requirement to overhang the box gutter into the Dam Buster Sump and therefore the box gutter should finish flush with the internal end of the gutter receiver component of the Dam Buster Sump. Staggered rivets spaced at maximum 40mm intervals should be installed to secure the box gutter to the gutter receiver component of the Dam Buster Sump. Apply Roof & Gutter silicone over the top of all rivets to seal.
8. Flash around the Dam Buster Sump if required and/or trim to suit box gutter heights, ensuring that the Dam Buster Sump fits tightly underneath the roof sheeting. Extra flashing installation may be required to achieve this.
9. For the Back-to-Back Sump arrangement (Diagram Y) the installation of a link between the box gutters is required. The rear walls of both sumps are cut down by 60mm, and a flashing (supplied by the roof plumber) is installed over the rear walls. Profile cut plates, supplied with each Dam Buster Sump, are then installed on both inner faces of the vertical walls of the sumps. Install rivets in the pre-drilled holes in the profile cut plates, and then apply Roof & Gutter silicone as required to ensure seal is obtained.
10. For the Continuous Sump arrangement (as per Diagram Z), the downstream gutter receiver is used as the stop end for the upstream end of the downstream box gutter, which abuts the Dam Buster Sump. The end wall of the Dam Buster Sump should then be cut down by 60mm and a 60mm section of the total width of the Dam Buster Sump downstream gutter receiver is folded over into the sump, sealed and riveted into position, using the profile cut plates supplied with each sump. Install rivets in the pre-drilled holes in the profile cut plates, and then apply Roof & Gutter silicone as required to ensure seal is obtained.
11. Where a catchment of water falling directly into the overflow chamber may cause nuisance by discharging out of the overflow pipe, a Sump Cover can be ordered for installation above the overflow chamber to deflect catchment into the main outlet chamber only. Sump Cover to be installed by using the fold down tabs which are on 3 x sides to suspend Cover at the correct position above the top of the overflow chamber (and tucked under surrounding roof sheet ends and flashings). Install rivets into pre-drilled rivet holes to secure Sump Cover and seal over rivets.

3.0 Installation Instructions for Dam Buster Sump (cont.)

12. Advise Property Owners of the requirement of Australian Standards (AS/NZS 3500.3; Section 3.2, NOTE 3 and Clause M.5, Appendix M) for the regular maintenance of the roof drainage system (i.e. cleaning of any accumulated debris from the box gutter and rainhead on a regular basis). Educate Property Owner regarding the 'visual alert' of the operation of the Dam Buster Sump overflow indicating that there is a blockage requiring urgent clearing.

NOTE: It is the licensed roof plumber's responsibility to certify all works associated with the installation of the box gutters and Dam Buster devices in accordance with the specific requirements of that State or Territory.

90MM DIAM. (OR EQUIV. SIZED)
FULL BLOCKAGE
OVERFLOW INDICATOR
THRU EXTERNAL WALL
TO ATMOSPHERE
(NON CONTINUOUS SUMP).
ROOF PLUMBER TO SUPPLY.

Protected by various Australian and International patents

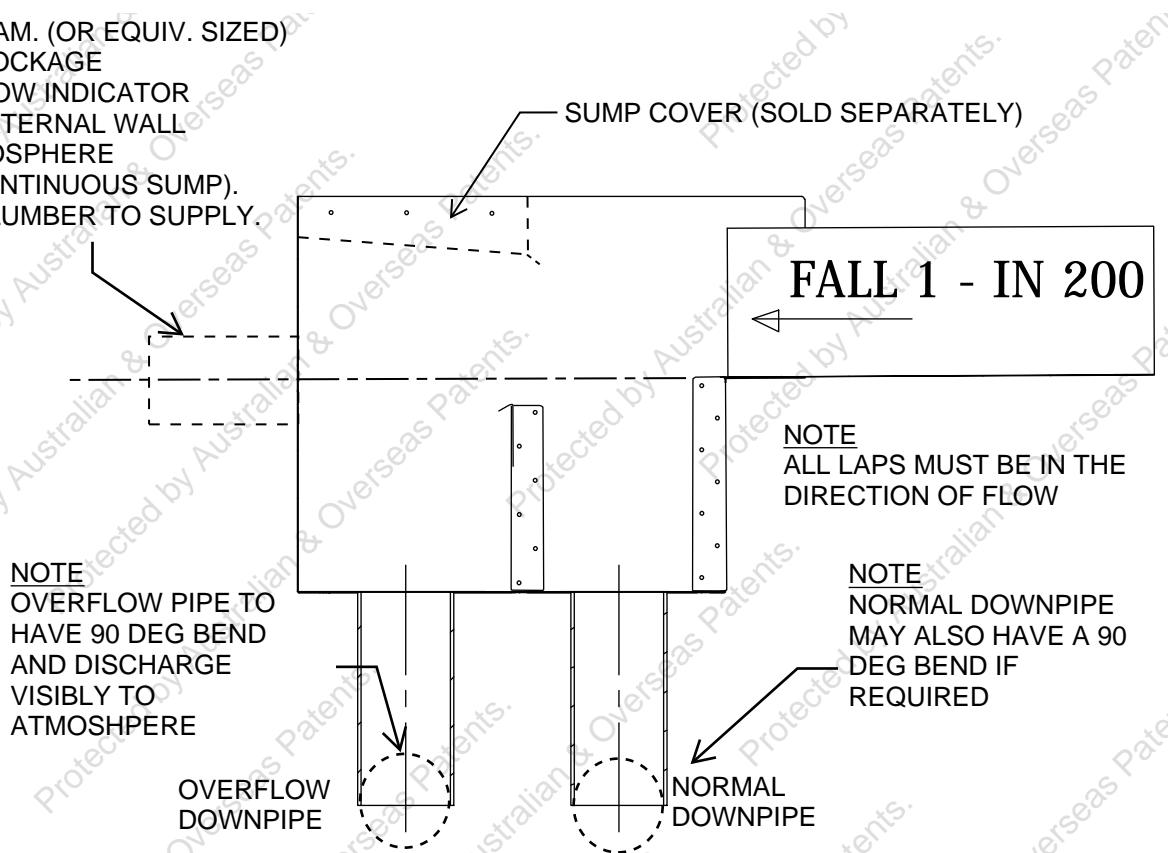
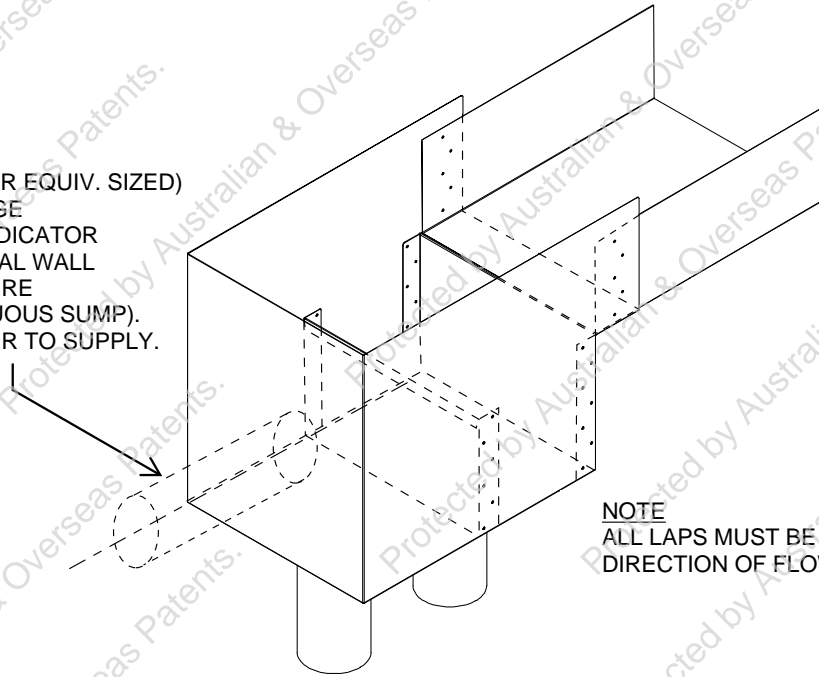

DIAGRAM 'V'
SECTION THROUGH DAM BUSTER SUMP

90MM DIAM. (OR EQUIV. SIZED)
 FULL BLOCKAGE
 OVERFLOW INDICATOR
 THRU EXTERNAL WALL
 TO ATMOSPHERE
 (NON CONTINUOUS SUMP).
 ROOF PLUMBER TO SUPPLY.



NOTE
 ALL LAPS MUST BE IN THE
 DIRECTION OF FLOW

DIAGRAM 'W' ATTACHMENT OF BOX GUTTER TO SUMP

Protected by various Australian and International patents

Protected by various Australian and International patents

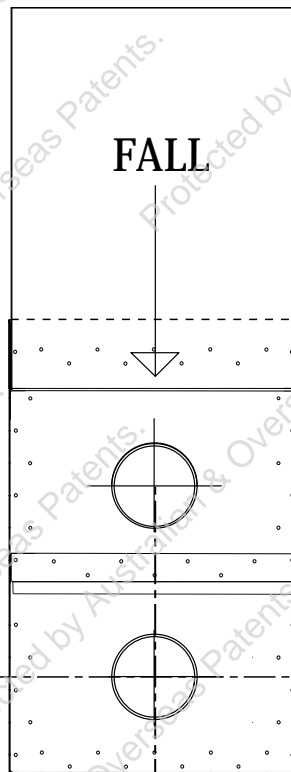

NOTE
 ALL LAPS MUST BE IN THE
 DIRECTION OF FLOW

90MM DIAM. (OR EQUIV. SIZED)
 FULL BLOCKAGE
 OVERFLOW INDICATOR
 THRU EXTERNAL WALL
 TO ATMOSPHERE
 (NON CONTINUOUS SUMP)

NOTE
 AN ALTERNATIVE LOCATION
 FOR THE FULL BLOCKAGE
 OVERFLOW INDICATOR
 IS THROUGH A SIDE WALL

DIAGRAM 'X'

PLAN VIEW OF SUMP & BOX GUTTER

3.0 Installation Instructions for Dam Buster Sump (cont.)

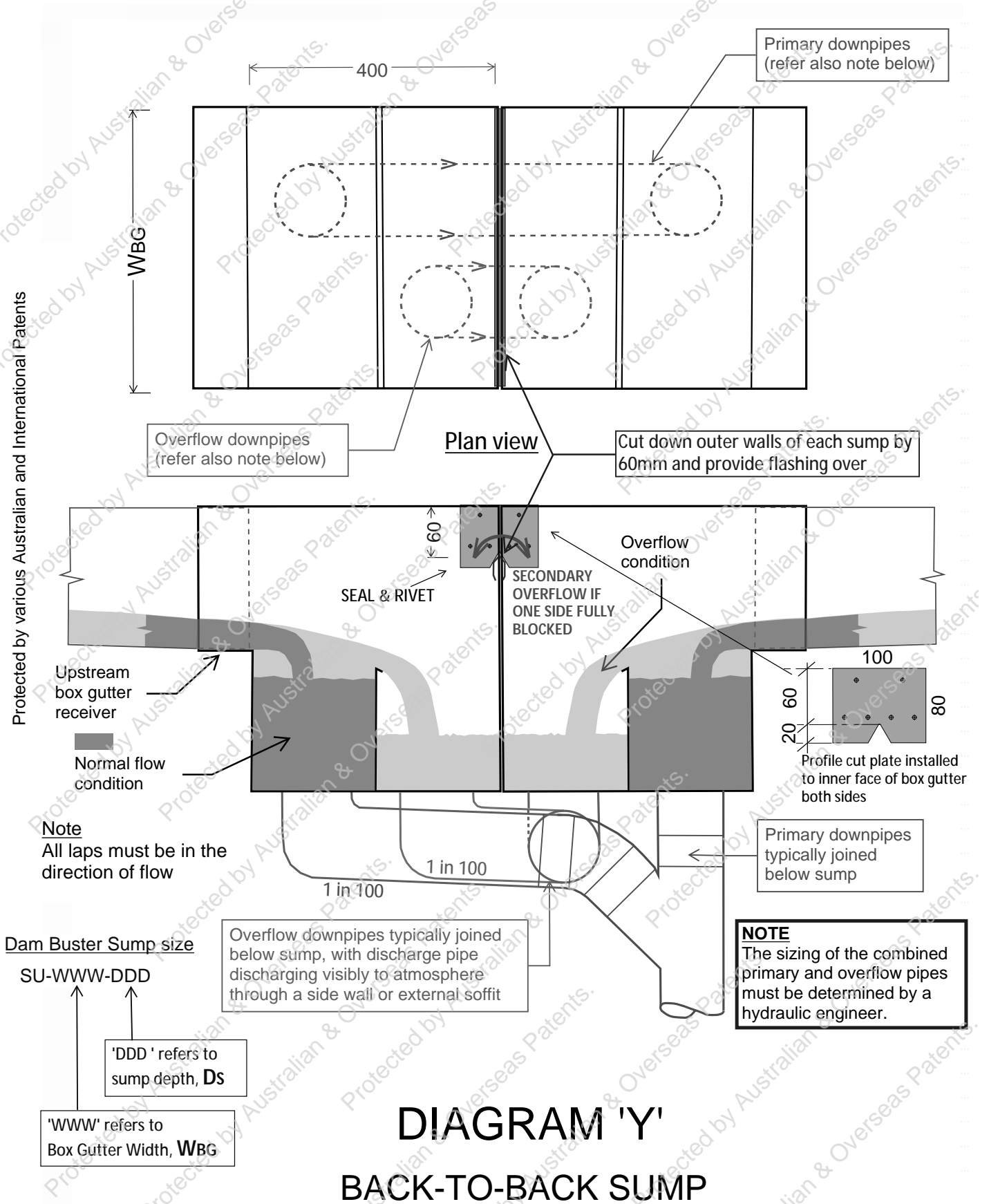
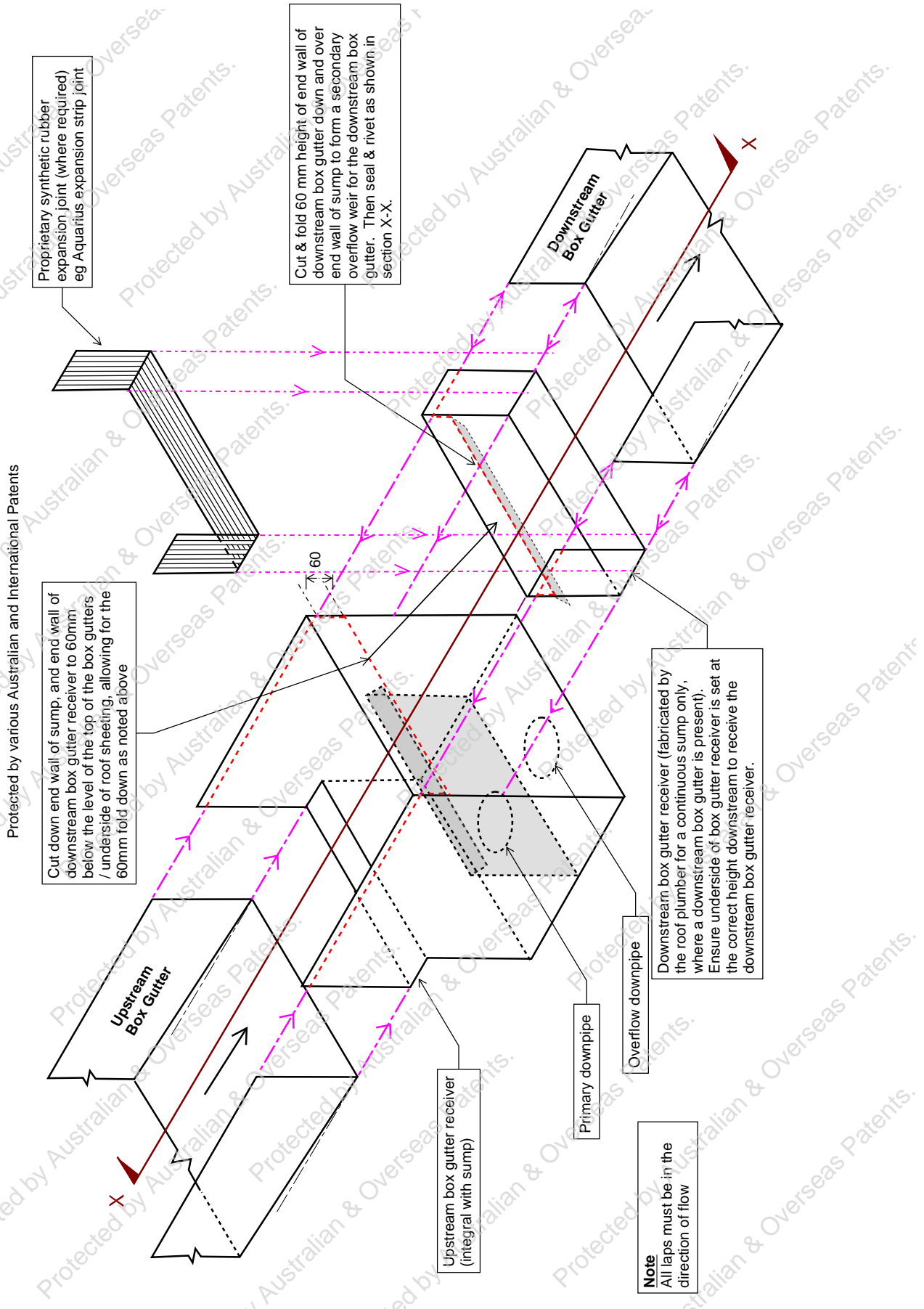
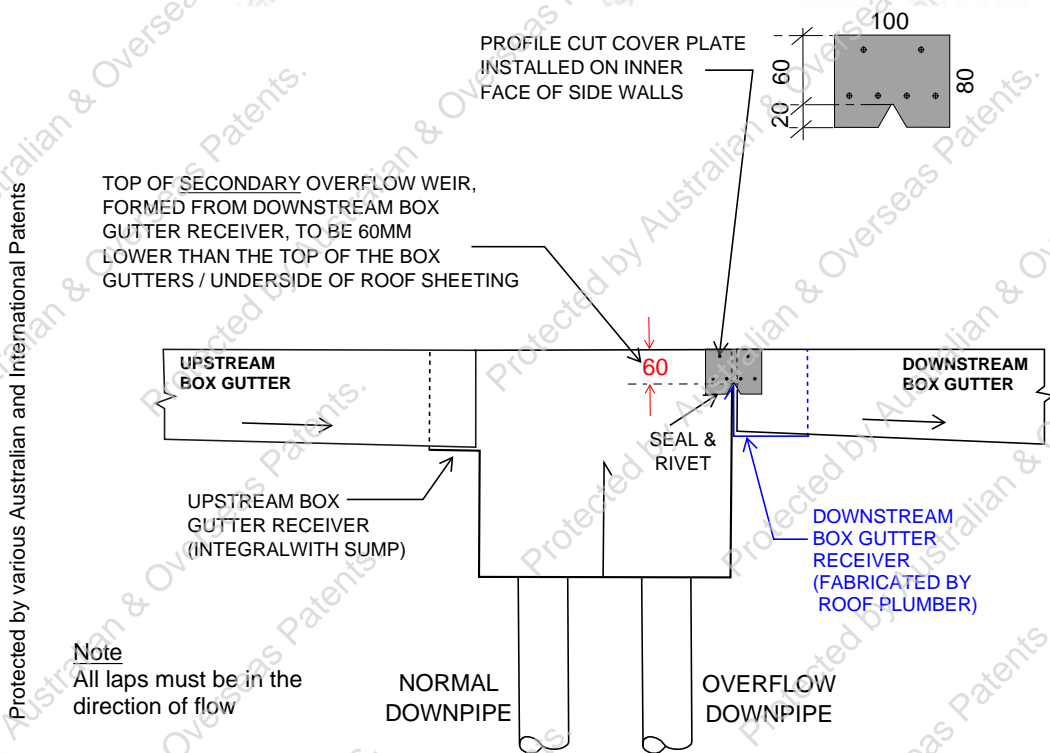

DIAGRAM 'Y'
BACK-TO-BACK SUMP

3.0 Installation Instructions for Dam Buster Sump (cont.)



3.0 Installation Instructions for Dam Buster Sump (cont.)



SECTION X-X as installed
(NO expansion joint)

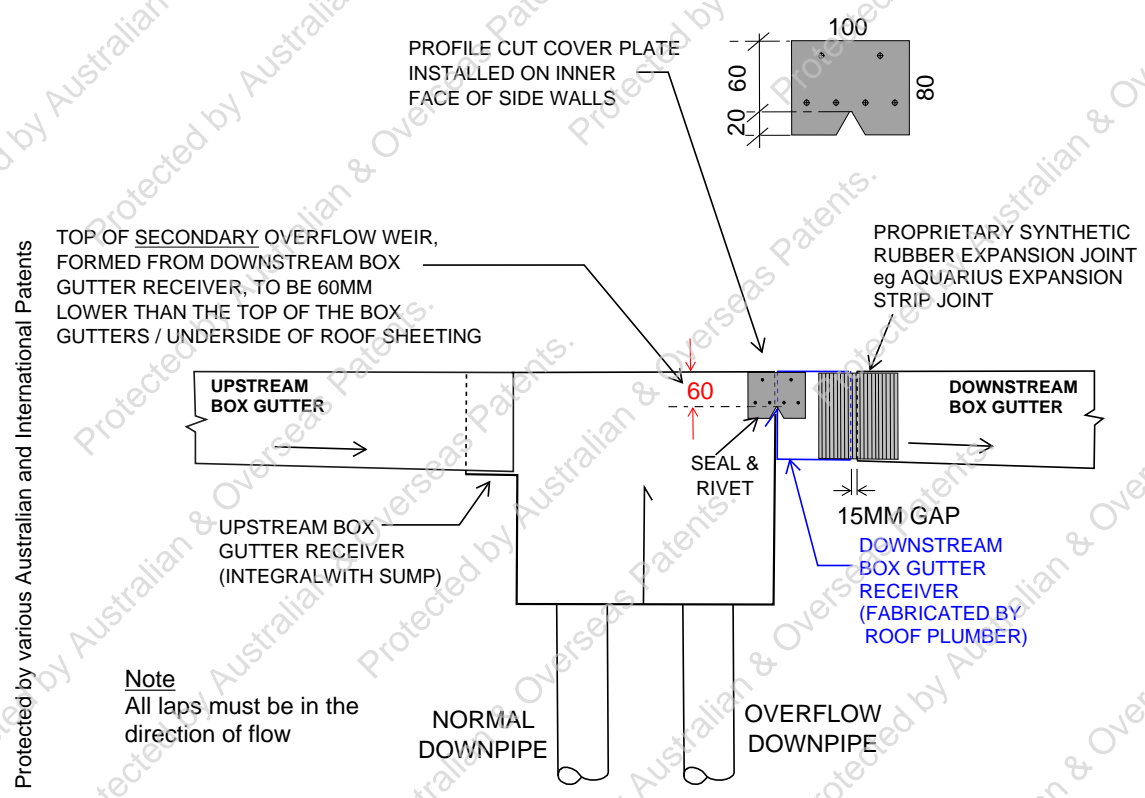

SECTION X-X as installed
(WITH expansion joint)

4.0 Installation Instructions for Dam Buster Upstream devices

4.1 Dam Buster Elbow

4.1 General information on Dam Buster Elbows is provided below. Refer to section 4.2 for the installation instructions.

Dam Buster Elbow configuration options:

- Dam Buster **Fixed** Elbow (RH or LH) (see Diagram D)
- Dam Buster **Sliding** Elbow (RH or LH) (see Diagram E)

Notes

- The **Fixed** Elbow is only suitable for **NEW** installations where the width of the box gutter does not change.
- The **Sliding** Elbow is suitable for **NEW** installations where the upstream gutter is not as wide as the downstream gutter.
- The Sliding Elbow is also suitable for **RETROFITTING** in relation to an existing roof. When retrofitting, an additional short 'stub tapered box gutter' is recommended to assist with ease of installation, noting that all box gutters must be lapped in the direction of fall i.e. the upstream box gutter must be fitting into the downstream box gutter. Refer to Diagram D.

Dam Buster Fixed Elbow sizes for box gutter widths:

- [ELB-200](#) Elbow
- [ELB-300](#) Elbow
- [ELB-400](#) Elbow
- [ELB-500](#) Elbow
- [ELB-600](#) Elbow

Dam Buster Sliding Elbow sizes for box gutter widths:

- [ELB-200](#) - for box gutter width **200mm** only. Note, the sliding version in this case allows for minor adjustment only.
- [ELB-300](#) - adjusts to suit upstream box gutters from **300mm to 200mm** in width.
- [ELB-400](#) - adjusts to suit upstream box gutters from **400mm to 300mm** in width.
- [ELB-500](#) - adjusts to suit upstream box gutters from **500mm to 300mm** in width.
- [ELB-600](#) - adjusts to suit upstream box gutters from **600mm to 400mm** in width.
- ***IMPORTANT NOTES***
 - i. All Elbows are supplied as two-piece / Sliding by default. 'Fixed' Elbows can be supplied for special larger volume orders (over 20 units).
 - ii. The Dam Buster Elbow must not be used outside the above ranges.
 - iii. The Dam Buster Elbow can be used with a narrower width box gutter upstream compared to the downstream width.

4.0 Installation Instructions for Dam Buster Upstream devices

4.2 Installation of the Dam Buster Elbow

IMPORTANT NOTE: Before proceeding you must always correctly select the Dam Buster Elbow to suit the design flow rate in litres / sec for the roof catchment area. Refer to the Dam Buster **Product Technical Statement** for roof catchment area calculations and Elbow flow capacities.

YOU WILL NEED:

- 4-2 or 4-1 size 3.2mm (1/8th) diameter 1.6 - 3.2mm grip appropriately corrosion resistant pop rivets (sealed rivets preferable and colour matched where required)
- Hand riveter or power riveter.
- 3.2mm (1/8th inch) drill bit and small battery drill
- Silicone gun and 1 x tube of Roof & Gutter Silicone (colour matched)
- Spirit Level
- Clean rags
- Set Square
- Pencil

NOTE – MECHANICAL FASTENERS

Dam Buster recommends only rivets be used as the mechanical fasteners (i.e. not screws) for joining box gutters and installing Dam Buster devices. Rivets must always be installed such that the heads of the rivets are flush with the inner surface (water face) of the box gutter. Cover rivet head with silicone.

1. Preliminaries

- (a) Measure the width of the box gutter that will be entering the Dam Buster Elbow. Select the appropriate Elbow to suit the box gutter width.
- (b) The roof carpentry structure must provide adequate support for both the box gutter and the Dam Buster Elbow. The Dam Buster Elbow has in-built gradient of 1:200 which equates to 5mm over 1m and this needs to be accommodated by the carpentry support structure.

***NOTE:** Some small amount of adjustment may be required to the roof carpentry support structure when fitting the adjustable component of the Dam Buster Sliding Elbow to ensure it sits neatly and maintains the 1:200mm gradient. Therefore, dry fitting of the product prior to final installation is highly recommended.*

4.0 Installation Instructions for Dam Buster Elbow (cont)

4.1 Dam Buster Elbow (cont.)

2. New Installations – Fixed or Sliding Elbow

- (a) The downstream box gutter should be installed first, followed by the Dam Buster Elbow. The upstream section of the Dam Buster Elbow can then be installed. This is the portion which sits wholly within the drop-down sump space of the device. It is recommended that the upstream section is dry fitted and marked in position with a pencil onto the downstream section of the device to ensure a neat and tidy fit.
- (b) Silicone is then applied to the lapped portion of the downstream section of the device and the upstream section can then be fitted and riveted using the pre-drilled staggered rivet formation. Do not fix the Elbow or box gutter components to the structure so as to allow for expansion / contraction.
- (c) Apply 2 x Roof & Gutter silicone beads on both the base and walls of the box gutter receiving seal component of the Dam Buster Elbow to form a silicone 'sandwich' between the metal components. The box gutter can then be lowered into position on top of this seal with the end of the box gutter flush with the step (drop down) edge. Do not over-hang the box gutter into the sump space of the Dam Buster Elbow. It should finish flush with the step.
- (d) A staggered pattern of rivets at 40mm maximum intervals needs to be drilled and fixed into the base and side walls of the box gutter.
- (e) All exposed rivet heads to be neatly and thoroughly covered by Roof & Gutter silicone – either colour-matched if required or otherwise aluminium coloured.

3. Retrofitting installations – Sliding Elbow Only

- (a) Dam Buster Elbows (sliding) can either be installed prior to a box gutter installation (preferable) or, if required, they can be retrofitted into an existing box gutter installation.

*NOTE: If retrofitting of the Dam Buster Elbow is a necessity, then extra care is required in relation to the riveting and sealing of the connection between the existing box gutter and the Dam Buster Elbow. Refer to **Diagram 6** for a recommended retrofitting method, which involves the usage of an additional 'stub box gutter' to assist with the installation process.*

4.0 Installation Instructions for Dam Buster Elbow (cont)

4.1 Dam Buster Elbow (cont.)

4. Trimming the Dam Buster Elbow

The depth of the Dam Buster Elbow must be determined by the depth of the upstream ('upper') box gutter, at its downstream end (i.e. at the Elbow). This depth must be determined using the **Dam Buster Product Technical Statement** and this design value sets the depth for the upstream end of the downstream (or 'lower') box gutter.

5. Fixings – Dam Buster Fixed Elbow & Dam Buster Sliding Elbow

Apply 2 x Roof & Gutter silicone beads on both the base and walls of the box gutter receiving seal component of the Dam Buster Elbow. The box gutter can then be lowered into position on top of this seal with the end of the box gutter flush with the step (drop down) edge. No need to over-hang the box gutter into the sump space of the Dam Buster Side Outlet. It should finish flush with the step.

A staggered pattern of rivets at 40mm maximum intervals needs to be drilled and fixed into the base and side walls of the box gutter.

All exposed rivet heads to be neatly and thoroughly covered by Roof & Gutter silicone – either colour-matched if required or otherwise aluminium coloured.

6. Maintenance

Advise Property Owners of the requirement of Australian Standards (AS/NZS 3500.3; Section 3.2. NOTE 3, and Clause M.5, Appendix M) for the regular maintenance of the roof drainage system (i.e. cleaning of any accumulated debris from the box gutter and rainhead on a regular basis).

NOTE: It is the licensed roof plumber's responsibility to certify all works associated with the installation of the box gutters and Dam Buster devices in accordance with the specific requirements of that State or Territory.

4.2 Dam Buster Junctions

The Dam Buster Tee Junction and Dam Buster Corner Junction are installed in a similar manner to the Dam Buster Elbows.

4.0 Installation Instructions for Dam Buster Elbow (cont.)

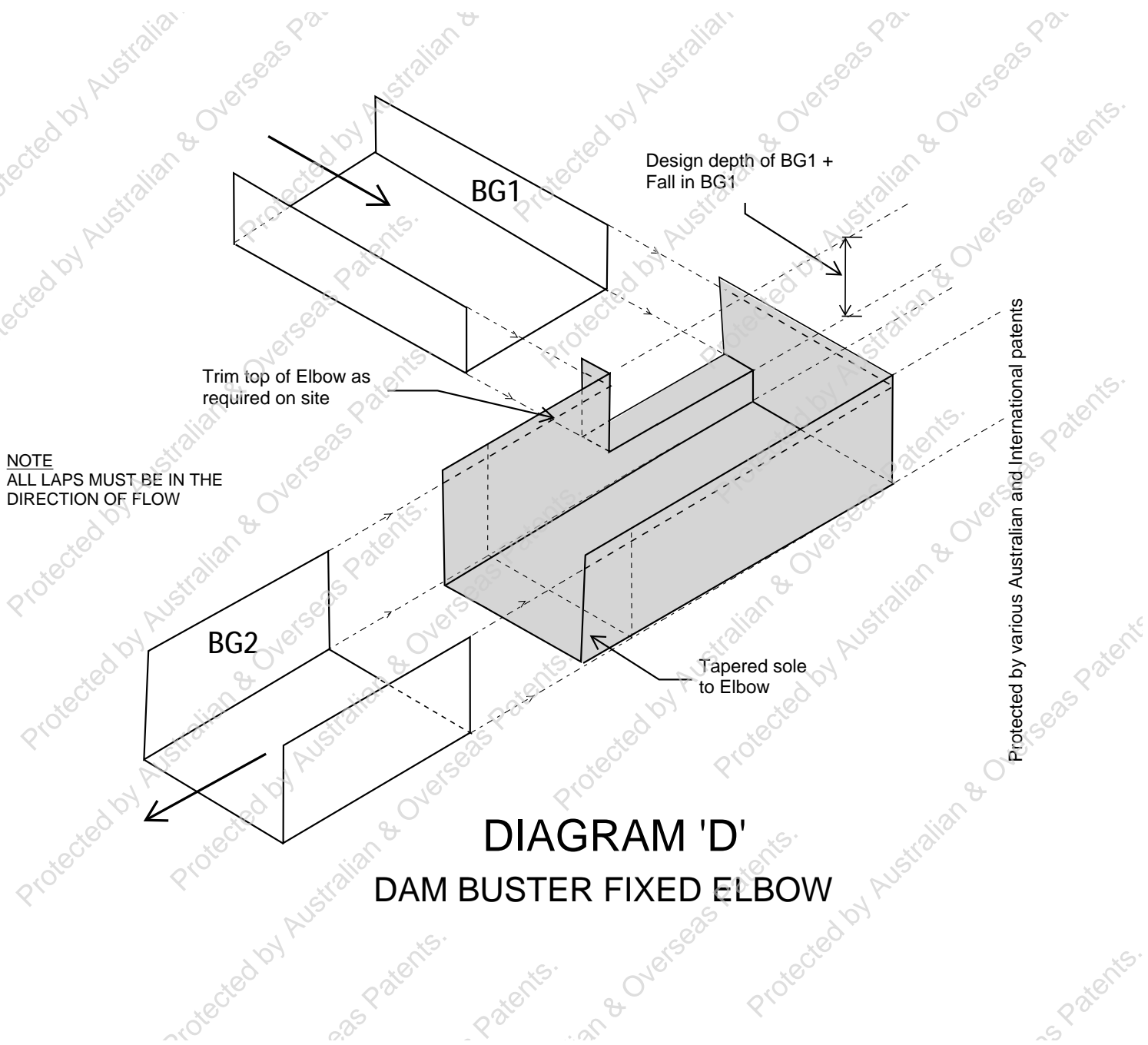

4.0 Installation Instructions for Dam Buster Elbow (cont)

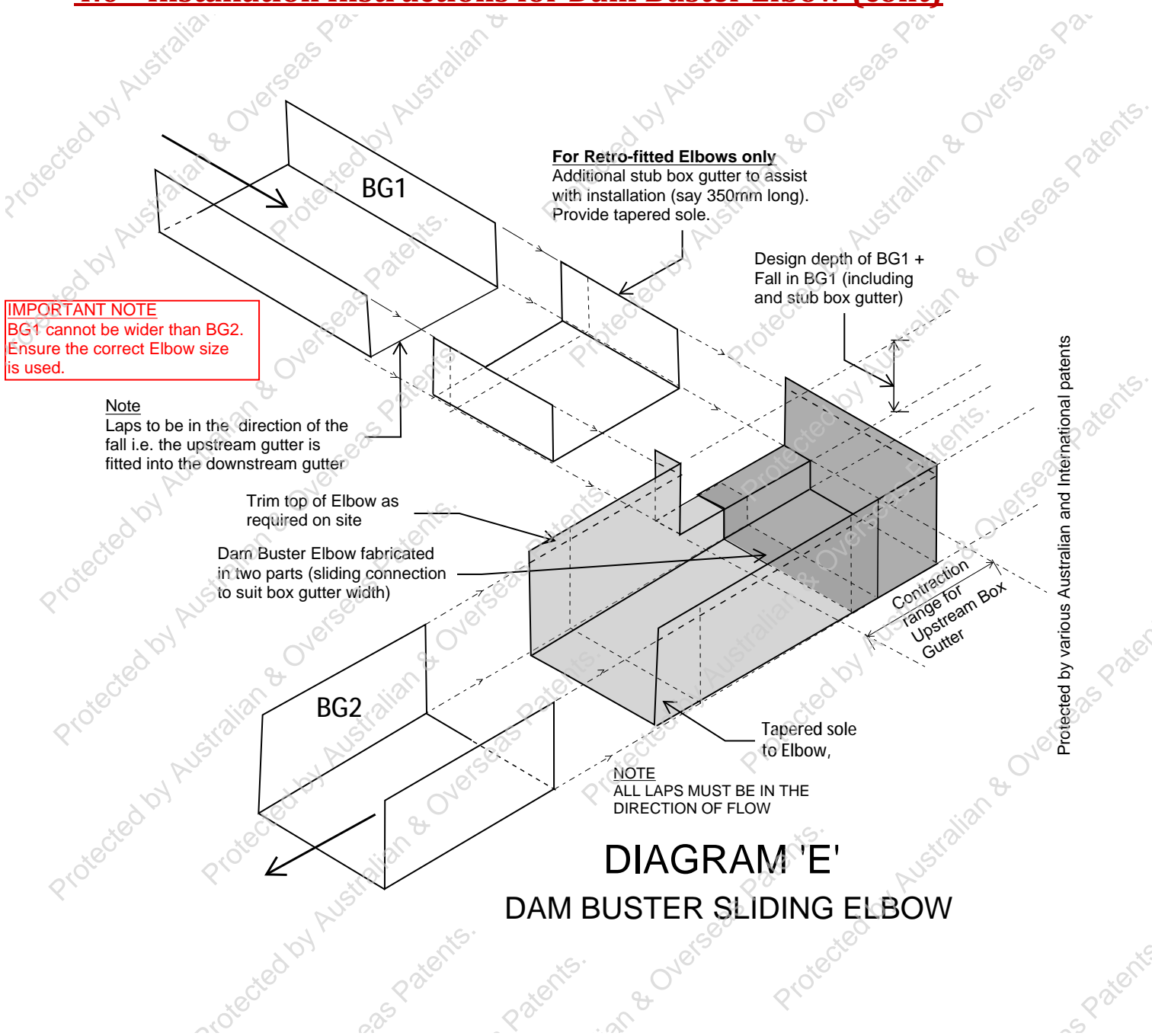

NOTE
REFER ALSO **DIAGRAM 6 ON PAGE 27** FOR DETAILS